



Clarity Dashcams

Installation Guide

EROAD

IMPORTANT

The packaging has a QR code necessary for registration, and it may contain smaller, overlooked items. Do not discard until the installation is complete.



Clarity Solo Kit (STD)

- » Main power cable
- » MicroSD card (pre-installed)
- » ATOF 32 V / 2 A blade fuses x2
- » Fuse holders x2
- » Lens covers x2
- » Cable ties x2

HR003108A Windshield kit

- » Windshield mounting plate (with adhesive pad)
- » Cleaning wipe
- » Allen/Hex key (2mm)
- » EROAD Windshield sticker
- » I/O Port guard

Clarity Connected Kit

- » Everything in STD, + Windshield Kit, AND:
- » HR003101A 3-wire loom (No GPIOs), or
- » HR003100A loom, GPIO-ready, or
- » HR003105A loom, GPIO-ready, and/or
- » ECM Y-cable

GPIO Remote Record Button kit (HR003107A)

- » Remote Record button 2-wire attachment
- » Button O-ring
- » Mounting washer
- » Mounting nut
- » Cable ties x2
- » ATOF 32 V / 2 A blade fuse
- » Fuse holder

GPIO Remote Record button kit (HR003106A)

- » Remote Record button 2-wire connector
- » 12-2 wire loom
- » Button O-ring
- » Mounting washer
- » Mounting nut
- » Cable ties x2
- » ATOF 32 V / 2 A blade fuse
- » Fuse holder

There are no user-serviceable parts.

Dashcam Parts

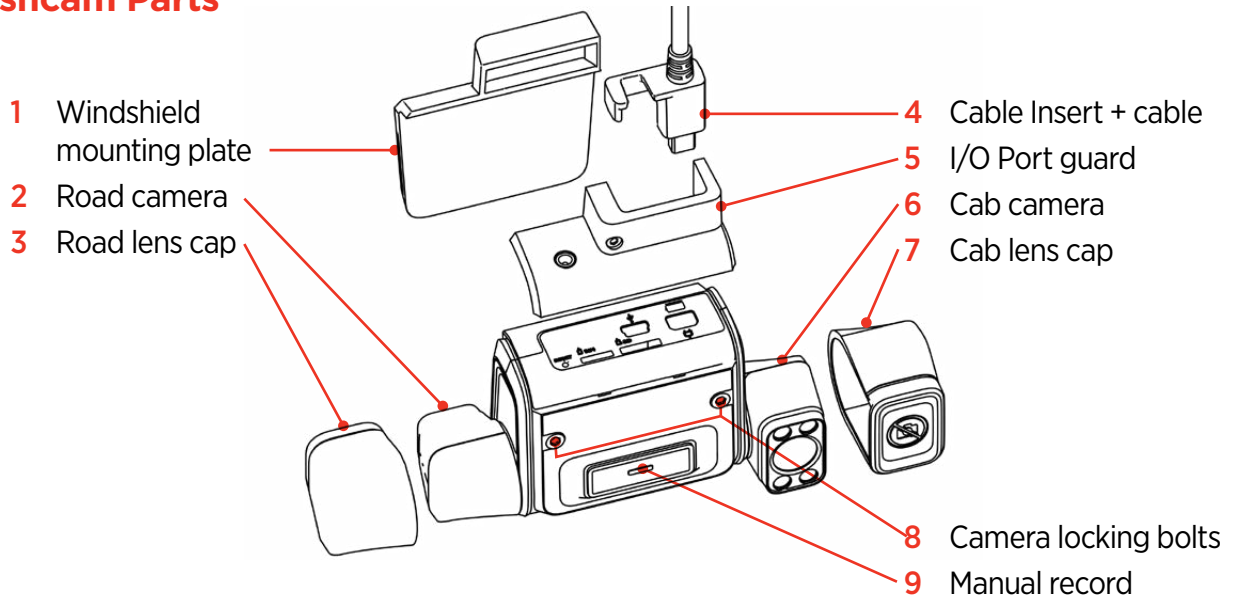

CAUTION

The Clarity cameras each have a RESTRICTED RANGE OF ROTATION. Do NOT attempt to rotate them with the locking bolts tightened, or past their tolerance limits (approximately 90° rotation for each camera).

Six step overview

- 1 Check you have the correct parts for your install.
- 2 Mount the dashcam to the windshield.
- 3 Run the cabling down the passenger-side A-Pillar.
- 4 Connect the dashcam to power/ECM and tidy cabling.
- 5 Run <https://install.eroad.com> and provision the dashcam.
- 6 Take site photos.

Installing Clarity Dashcams in vehicles with CoreHub in-cab devices

The ONLY install type for CoreHub in-cab systems is the 3-wire install using the HR003101A loom.

Clarity Dashcam does NOT connect to the CoreHub in-cab device at all.

Clarity connects to vehicle Power, GND and IGN.

Technicians perform the dashcam install process independently of the CoreHub in-cab install process described in the **CoreHub Installation and Maintenance Guide**.

Placement

Position the dashcam inside, in the approximate middle-top of the windshield, or if this location is already occupied, slightly passenger-side.

The front camera should be approximately 8 inches (20 cm) below the windshield wipers' highest sweep-point.

The unit should be mounted outside the driver's normal sight lines of the road ahead, highway signs, signals and all mirrors.

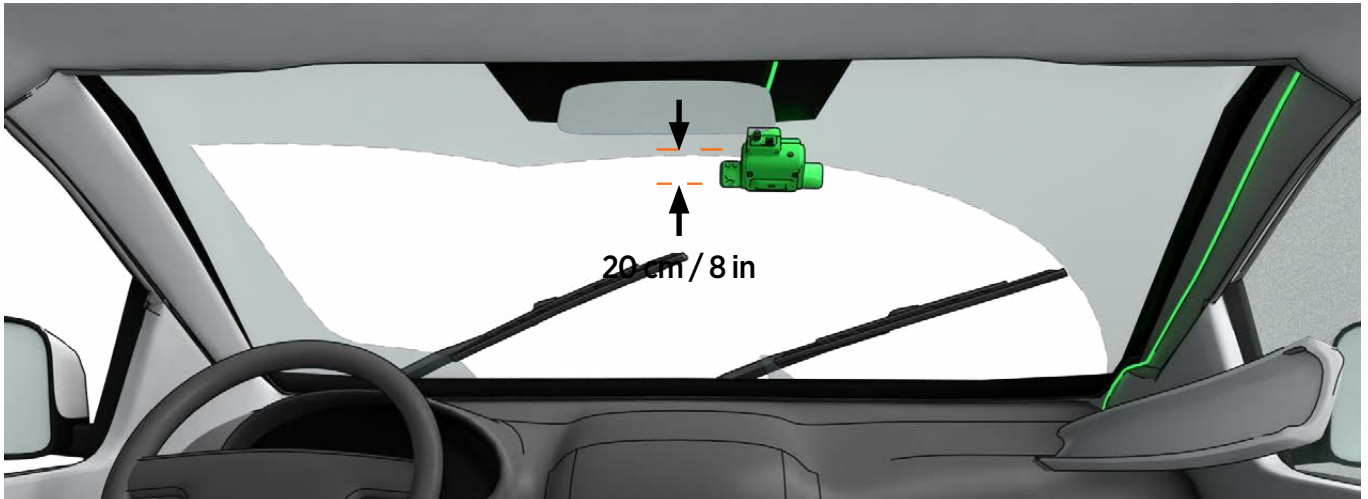

Mounting the Dashcam

- 1 Clean the mounting area with the alcohol wipe provided.
- 2 Re-wipe the area with a clean cloth to remove any residue.
- 3 Remove the adhesive paper from the mounting plate.
- 4 Alignment check:
 - » Ensure the pad orientation will hold the dashcam with the cable facing UP.
 - » The road-facing camera must not be blocked by existing ADAS units, toll tags, tints or sunshades, vehicle certifications, other decals or objects.
 - » The cab-facing camera should not be blocked by mirrors, internal shades or hanging items.
 - » The mounting plate is level with the horizon.
- 5 Press the MIDDLE of the mounting plate firmly into the windshield, working outwards, so the entire adhesive pad touches the windshield (you can better check this occasionally from outside the vehicle). Push firmly for 20s. Wait another 2 minutes for full adhesion.
- 6 Attach the dashcam body into the mounting plate. Leave the protective film on the lenses until the Install Wizard phase.

Fig.1: CORRECT Full contact with the mounting plate to the windshield. THEN, the main body is mounted.

Fig. 2: INCORRECT Dashcam should be mounted AFTER the mounting plate has fully stuck to the windshield.

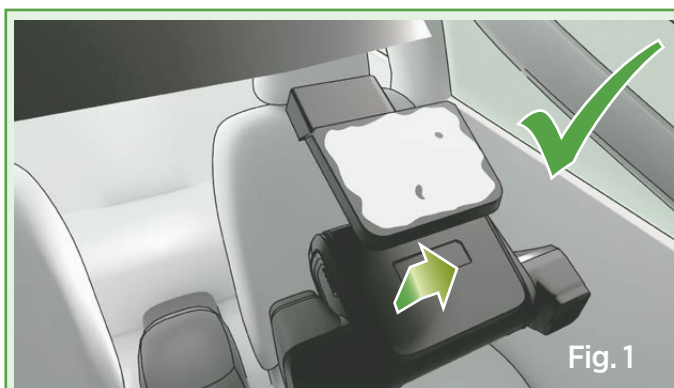

Fig. 1



Fig. 2

- 7 Plug the main cable into the dashcam. The cable should run:
 - » Across the top of the windshield out of sight.
 - » Down the windshield's A-pillar (out of sight, secured, tucked into the lining trim), down the back of the dashboard.
 - » In the shortest, most convenient path to your key connection points.
- 8 Find the vehicle's junction and/or fuse box under the dash. It's good practice to take a picture of the vehicle's current configuration to use as a reference later.
- 9 If attaching the Remote Record button, be aware that this can be fused on a separate circuit for vehicle power, or run off an existing fused power circuit.

Fig. 3: A-pillar removal. A-Pillar trim is commonly clipped in, or screwed under a handrail. Remove, run the cable down its length, and replace (**Fig. 4**).

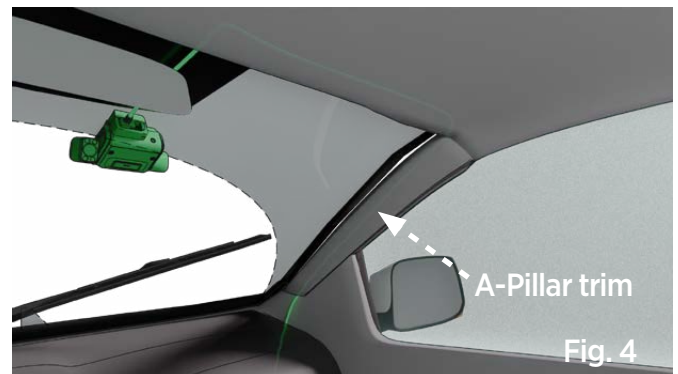
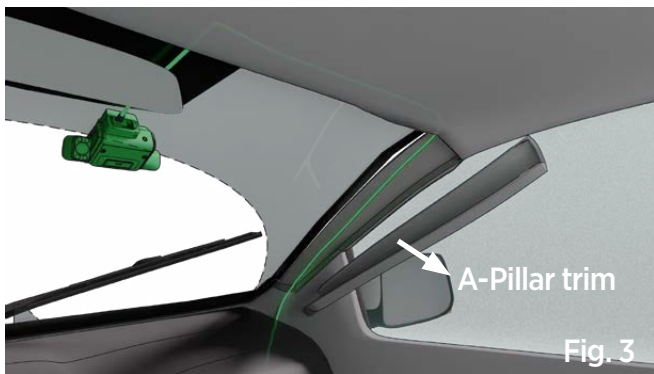

CAUTION

Assuming a "one way fits all" approach to fleet installation is dangerous. Different cabs have different windshield angles, cab configurations, wiper-blade positions and concerns around left/ right/ dual seating. It's important that you treat each cab with individual attention to detail.

3-wire Install Using the HR003101A Loom (No GPIOs)

This is the only method for CoreHub installs, or any Clarity stand-alone installs.

The diagram shows a basic connection for the Clarity dashcam using the HR003101A 3-wire loom.

- » RED wire fused to vehicle DC power.
- » YELLOW/RED wire fused to Ignition.
- » BLACK wire to Ground.

Note 1 Always seal wiring connections with heat shrink and/or electrician's tape.
Do not cut cables - Coil and tie them out of the way.

- 1 Connect the 12-way connector from the Dashcam to the 12-way connector on the 12-way wiring loom. Secure with electrical tape.
- 2 Connect the BLACK wire on the 12-way wiring loom to an appropriate grounding location.
- 3 Connect the RED wire on the 12-way wiring loom to a permanent power source.

Note 2 Ensure there is a constant 12-24 V when the key is inserted, with the engine running, and also when the key is not inserted and the engine is off.

- 4 Connect the RED/YELLOW-striped wire on the 12-way wiring loom to an ignition/switched power source.

Note 3 Ensure the ignition/switched power source supplies 12-24 V when the key is in the ON position and zero volts when the key is in the accessory (ACC) and OFF positions.

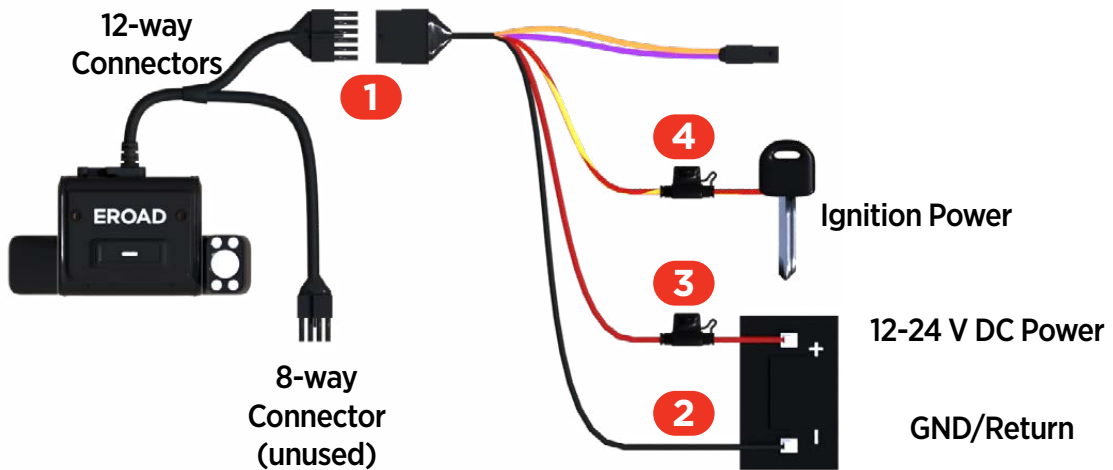

Dashcam Connected (Ehubo2 Only)

Consult the dedicated Ehubo Installation Guide for full instructions. But as a wiring check:

- 1 Connect the BLACK wire on the 10-way wiring loom to an appropriate grounding location.
- 2 Connect the RED wire on the 10-way wiring loom to a permanent power source.
- 3 Connect the YELLOW wire on the 10-way wiring loom to an ignition/switched power source.
- 4 See all notes above.

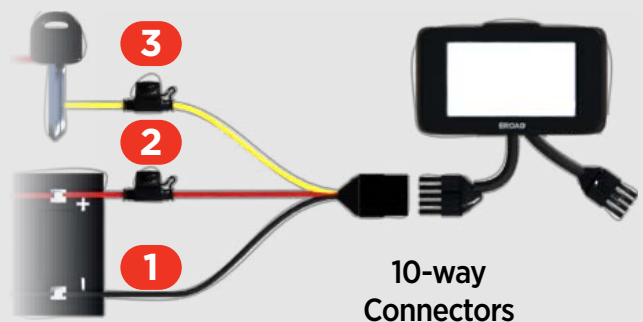

Remote record button install (HR003106)- Optional

Note 4 The 12-2 wire loom that comes with this remote button kit **IS NOT USED** for this install.

- 1 Drill a 14 mm (0.55 in) diameter hole into a dashboard panel (or similar site within comfortable reach of the driver).
- 2 Ensure the O-ring remains near the head of the button-thread while removing the nut and washer.
- 3 Thread the wires through the washer and nut.
- 4 Connect the 12-way wiring loom to the Remote Record button, using the 2-way connectors provided.

Note 5 Ensure there is a constant 12-24 V when the key is inserted, with the engine running, and also when the key is not inserted and the engine is off.

- 5 Tighten the nut and washer.
- 6 Use cable ties to coil and tie away any excess cable.

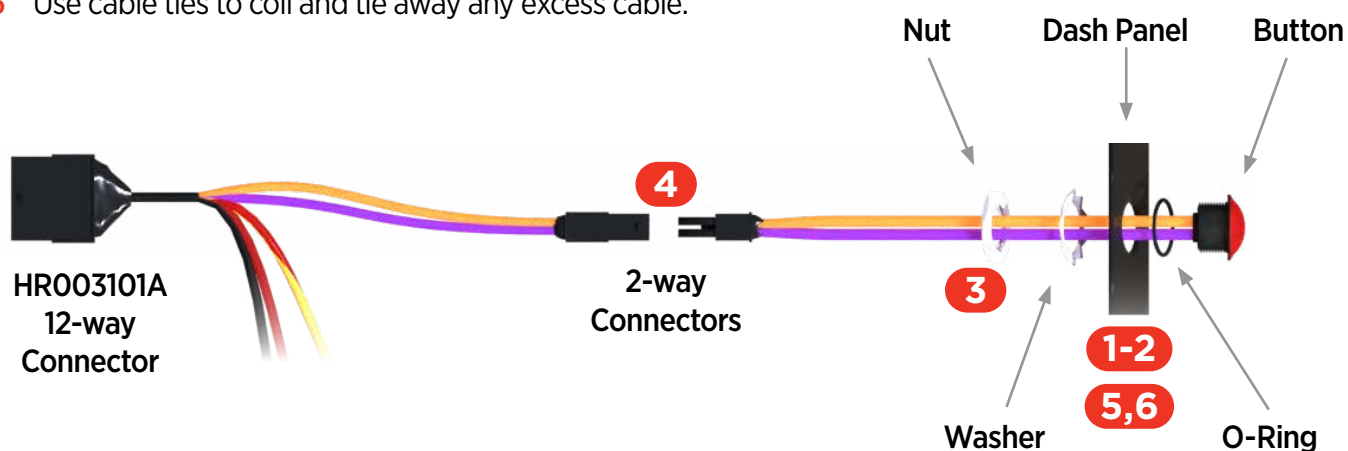

HR003101A 12-WAY PIN-OUT

1	GPIO input 1	Orange
2	Not Connected	
3	+ve power in	Red
4	Not Connected	
5	Not Connected	
6	Not Connected	
7	Ignition	Yellow/Red
8	Not Connected	
9	Not Connected	
10	Ground	Black
11	+ve power out	Purple
12	Not Connected	

2-WAY CONNECTOR PIN-OUT

1	+ve power out	Purple
2	GPIO1, input 1	Orange

This completes the basic 3-wire install type.

The following instructions only apply to other Ehubo2 Install types (eg. Hybrids, ECM), after which is the Configuration step.

[If you have completed
a 3-wire install for a
CoreHub in-cab or Ehubo2,
click here to skip to the
Configuration step.](#)

3-wire Install Using the HR003100A Loom (GPIO)

The diagram shows a basic connection for the Clarity Solo using the HR003100A 12-wire loom (as well as a basic Clarity Connected diagram for Ehubo2 devices only).

- » Red wire fused to vehicle DC power.
- » Yellow wire fused to Ignition.
- » Black wire to Ground.

Note 6 Always seal wiring connections with heat shrink and/or electrician's tape.
Do not cut cables - Coil and tie them out of the way.

- 1 Connect the 12-way connector from the Dashcam to the 12-way connector on the 12-way wiring loom. Secure with electrical tape.
- 2 Connect the BLACK wire on the 12-way wiring loom to an appropriate grounding location.
- 3 Connect the RED wire on the 12-way wiring loom to a permanent power source.

Note 7 Ensure there is a constant 12-24 V when the key is inserted, with the engine running, and also when the key is not inserted and the engine is off.

- 4 Connect the RED/YELLOW-striped wire on the 12-way wiring loom to an ignition/switched power source.

Note 8 Ensure the ignition/switched power source supplies 12-24 V when the key is in the ON position and zero volts when the key is in the accessory (ACC) and OFF positions.

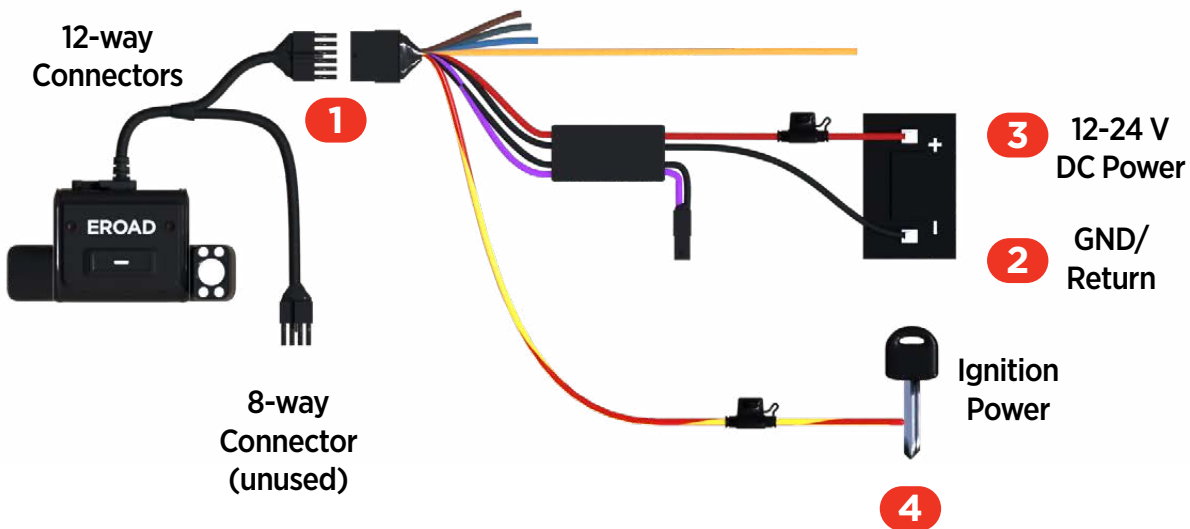

Dashcam Connected (Ehubo2 Only)

Consult the dedicated Ehubo Installation Guide for full instructions. But as a wiring check:

- 1 Connect the BLACK wire on the 10-way wiring loom to an appropriate grounding location.
- 2 Connect the RED wire on the 10-way wiring loom to a permanent power source.
- 3 Connect the YELLOW wire on the 10-way wiring loom to an ignition/switched power source.
- 4 See all notes above.

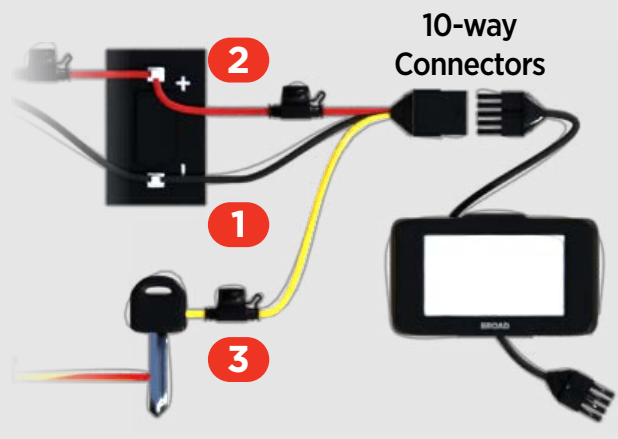

Remote record button install (Kit HR003107A) - Optional

- 1 Drill a 14 mm (0.55 in) diameter hole into a dashboard panel (or similar site within comfortable reach of the driver).
- 2 Ensure the O-ring remains near the head of the button-thread while removing the nut and washer.
- 3 Thread the wires through the washer and nut.
- 4 Wire up the ORANGE wire from the 12-way wiring loom to the to the ORANGE wire on the Remote Record button.
- 5 Fuse the RED wire to a permanent power source.

Note 9 Ensure there is a constant 12-24 V when the key is inserted, with the engine running, and also when the key is not inserted and the engine is off.

- 6 Tighten the nut and washer.
- 7 Use cable ties to coil and tie away any excess cable.

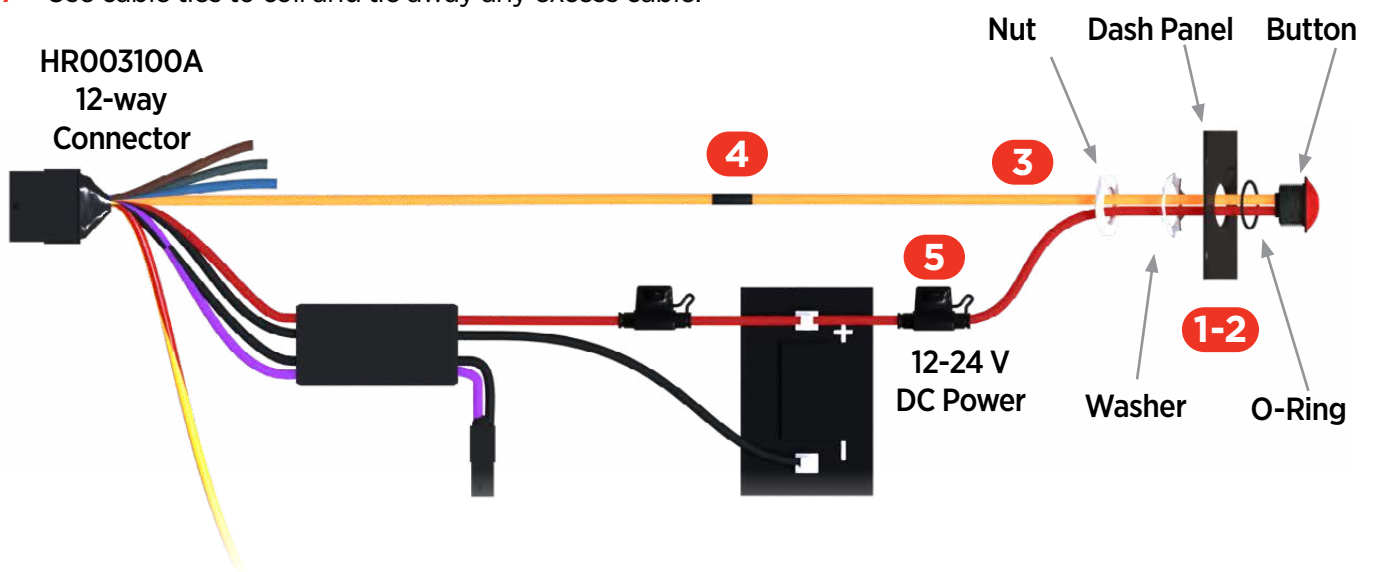

HR003100A 12-WAY PIN-OUT

- | | | |
|----|-----------------|-------------|
| 1 | GPIO1, input 1 | Orange |
| 2 | GPIO2, input 2 | Brown |
| 3 | +ve power in | Red |
| 4 | RS232_RX | Black/White |
| 5 | RS232_TX | White |
| 6 | GPIO3, input 3 | Grey |
| 7 | Ignition | Yellow/Red |
| 8 | GPIO4, output 4 | Blue |
| 9 | Not Connected | |
| 10 | Ground | Black |
| 11 | +ve power out | Purple |
| 12 | Ground | Black |

2-WAY CONNECTOR PIN-OUT

- | | | |
|---|----------------|--------|
| 1 | GPIO1, input 1 | Purple |
| 2 | GPIO2, input 2 | Black |

REMOTE BUTTON PIN-OUT

- | | | |
|---|----------------|--------|
| 1 | +ve power out | Red |
| 2 | GPIO1, input 1 | Orange |

Hybrid ECM Install Using the HR003105A Loom (GPIO)

The diagram shows a basic connection for Clarity Solo dashcams using the HR003105A 12-wire loom. If you are installing a Clarity Connected camera, your in-cab device is likely to be fused and connected already.

- » Power and ground is obtained from the vehicle's diagnostic port.
- » YELLOW/RED wire wire fused to Ignition.

Note 10 Always seal wiring connections with heat shrink and/or electrician's tape.
Do not cut cables - Coil and tie them out of the way.

- 1 Connect the 12-way connector on the main camera power cable to the 12-way connector on the 12-way wiring loom. Secure with electrical tape.
- 2 Connect the RED and YELLOW striped wire on the 12-way wiring loom to an ignition/switched power source.
- 3 Connect the 8-way connector on the main dashcam power cable to the 8-way connector on the dashcam ECM Y-cable. Secure with electrical tape.

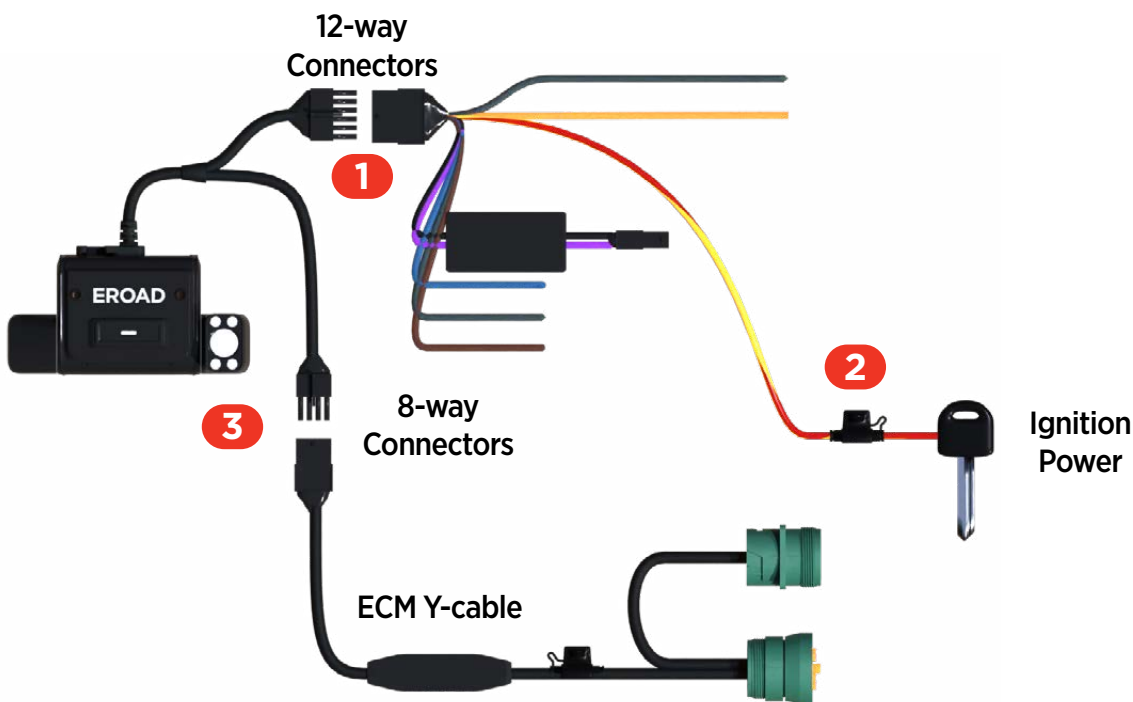

- 4 Locate the vehicle diagnostic port. This female connector will likely be built into a panel, and is typically found under the dash on the driver side, in the fuse panel, or behind a removable dash panel.

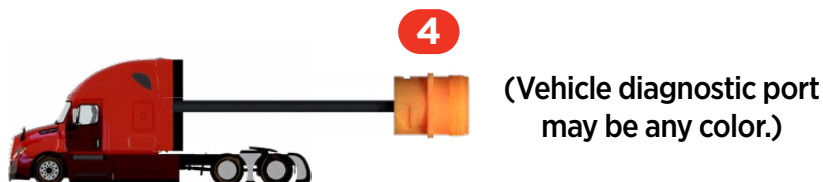

- 5 Unless this attached cable is another ECM Y-cable, detach it. If it is a Y-cable you could tap on to its free end and continue the chain. Insert the dashcam ECM Y-cable onto the free end of the existing ECM Y-cable. Ensure the cables are twist-locked and/or secured firmly.

Note 11 For Solo, the second Y-cable may not exist if there is no other hardware connected to the vehicle's diagnostic port.

- 6 Mount the last free female connector back into the vehicle diagnostic port.

Note 12 Ensure the ignition/switched power source supplies 12-24 V when the key is in the ON position, and zero volts when the key is in the accessory (ACC) and OFF positions.

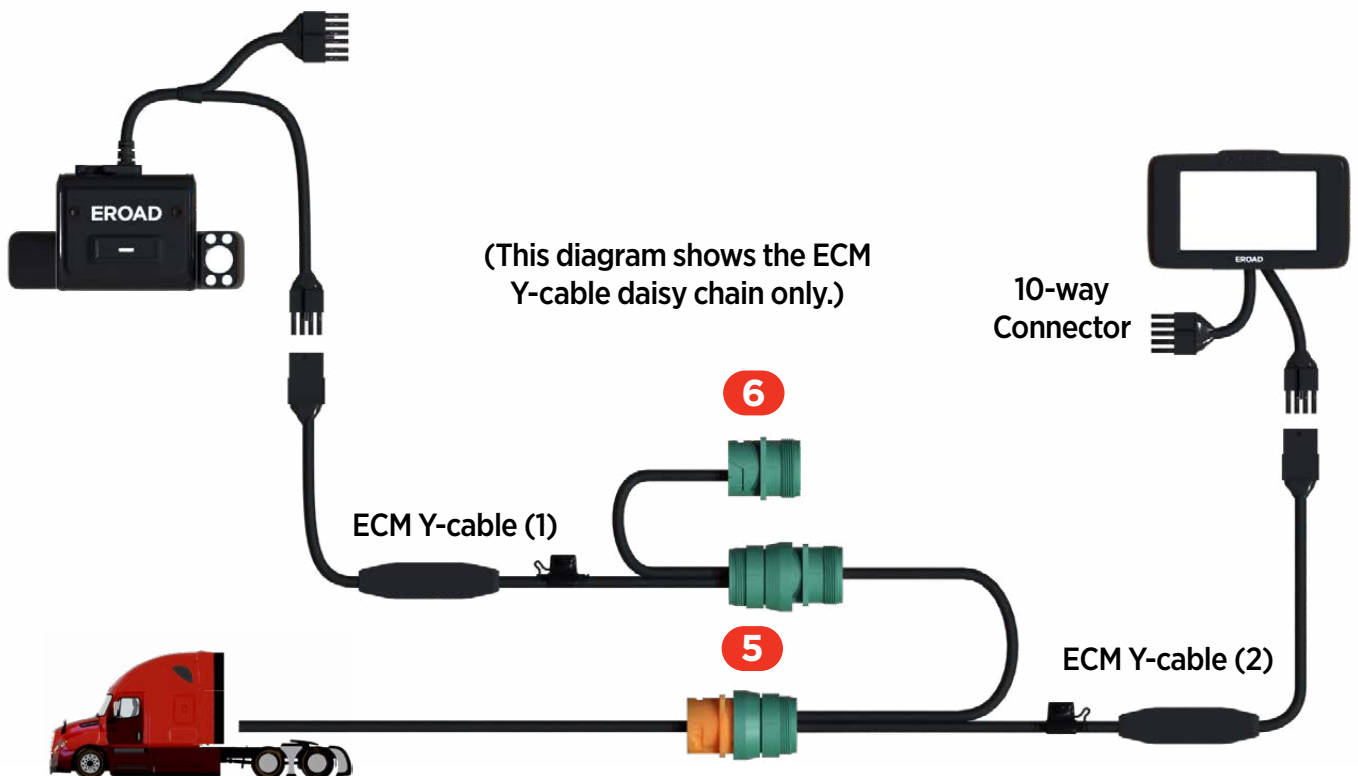

HR003105A 12-WAY PIN-OUT

1	GPIO1, input 1	Orange
2	GPIO2, input 2	Brown
3	Not Connected	
4	RS232_RX	Black/White
5	RS232_TX	White
6	GPIO3, input 3	Grey
7	Ignition	Yellow/Red
8	GPIO4, output 4	Blue
9	Not Connected	
10	Not Connected	
11	+ve power out	Purple
12	Ground	Black

2-WAY CONNECTOR PIN-OUT

1	GPIO1, input 1	Purple
2	GPIO2, input 2	Black

Remote record button install (Kit HR003107A) - Optional

- 1 Drill a 14 mm (0.55 in) diameter hole into a dashboard panel (or similar site within comfortable reach of the driver).
- 2 Ensure the O-ring remains near the head of the button-thread while removing the nut and washer.
- 3 Thread the wires through the washer and nut.
- 4 Wire up the ORANGE wire from the 12-way wiring loom to the ORANGE wire on the Remote Record button.
- 5 Fuse the RED wire to a permanent power source.

Note 13 Ensure there is a constant 12-24 V supply when the key is inserted, with the engine running, and also when the key is not inserted and the engine is off.

- 6 Tighten the nut and washer.
- 7 Use cable ties to coil and tie away any excess cable.

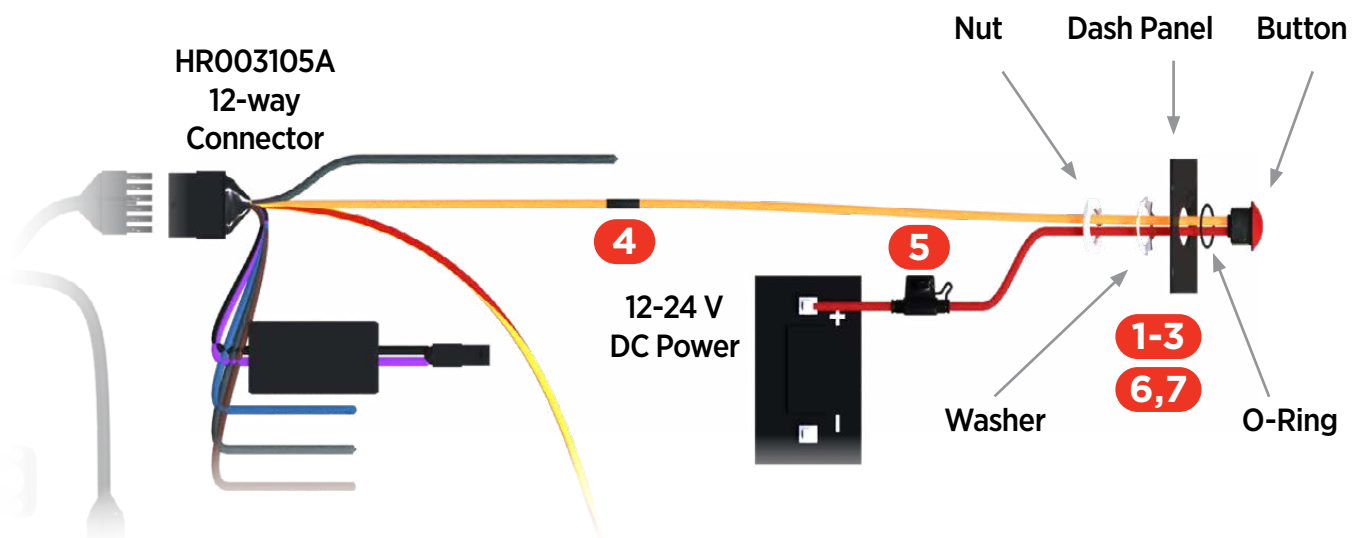

(This diagram does NOT show the ECM chain associated with this install type.)

Full ECM Install (non GPIO)

The diagrams show a basic connection for the Clarity Connected and Clarity Solo dashcams using a full ECM connection. If you are installing a Clarity Connected camera, your Ehubo or CoreHub is likely to be fused and connected already.

» Power, ground and ignition are obtained from the vehicle's diagnostic port.

Note 14 Always seal wiring connections with heat shrink and/or electrician's tape.
Do not cut cables - Coil and tie them out of the way.

- 1 Connect the 8-way connector on the main dashcam power cable to the 8-way connector on the dashcam ECM Y-cable. Secure with electrical tape.

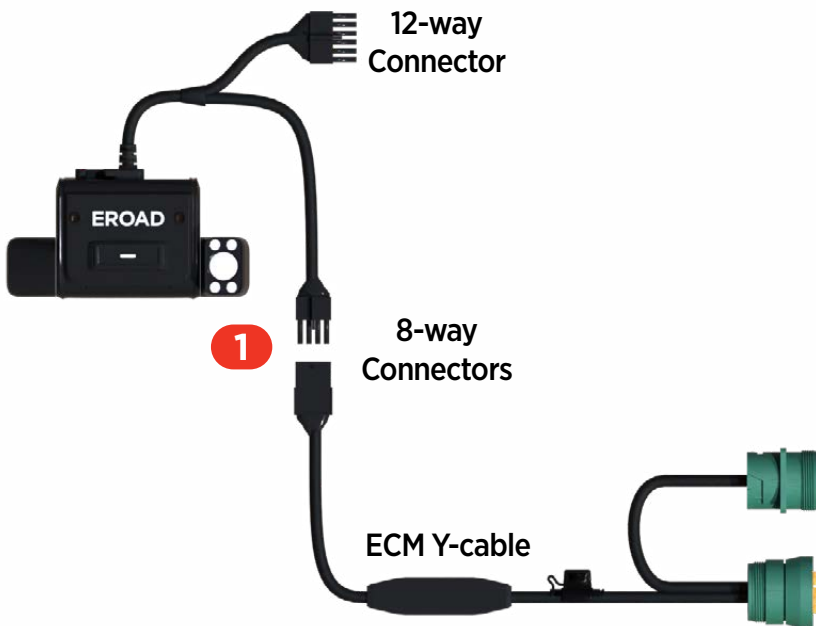

- 2 Locate the vehicle diagnostic port. This female connector will likely be built into a panel, and is typically found under the dash on the driver side, in the fuse panel, or behind a removable dash panel.

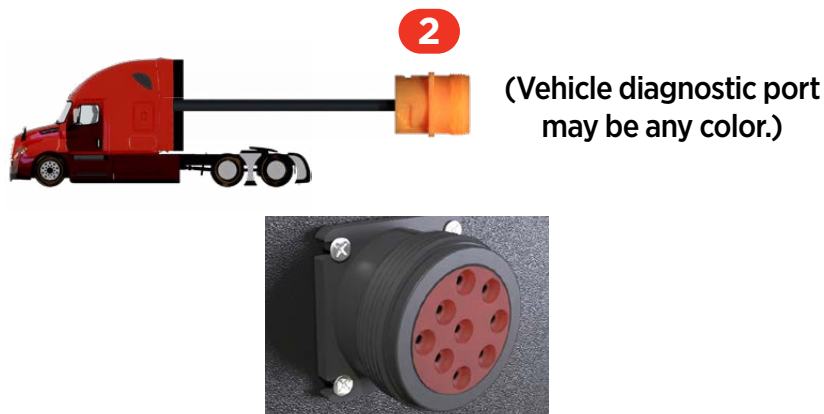

- 3 Unless this attached cable is another ECM Y-cable, detach it. If it is a Y-cable you could tap on to its free end and continue the chain.
- 4 Insert the dashcam ECM Y-cable onto the free end of the existing ECM Y-cable. Ensure the cables are twist-locked and/or secured firmly.

Note 15 For Solo, the second ECM Y-cable may not exist if there is no other hardware connected to the vehicle's diagnostic port.

- 5 **Dashcam Connected Only:** Connect the ECM Y-cable to the 8-way Ehubo connection.
- 6 Mount the last free female connector back into the vehicle diagnostic port.

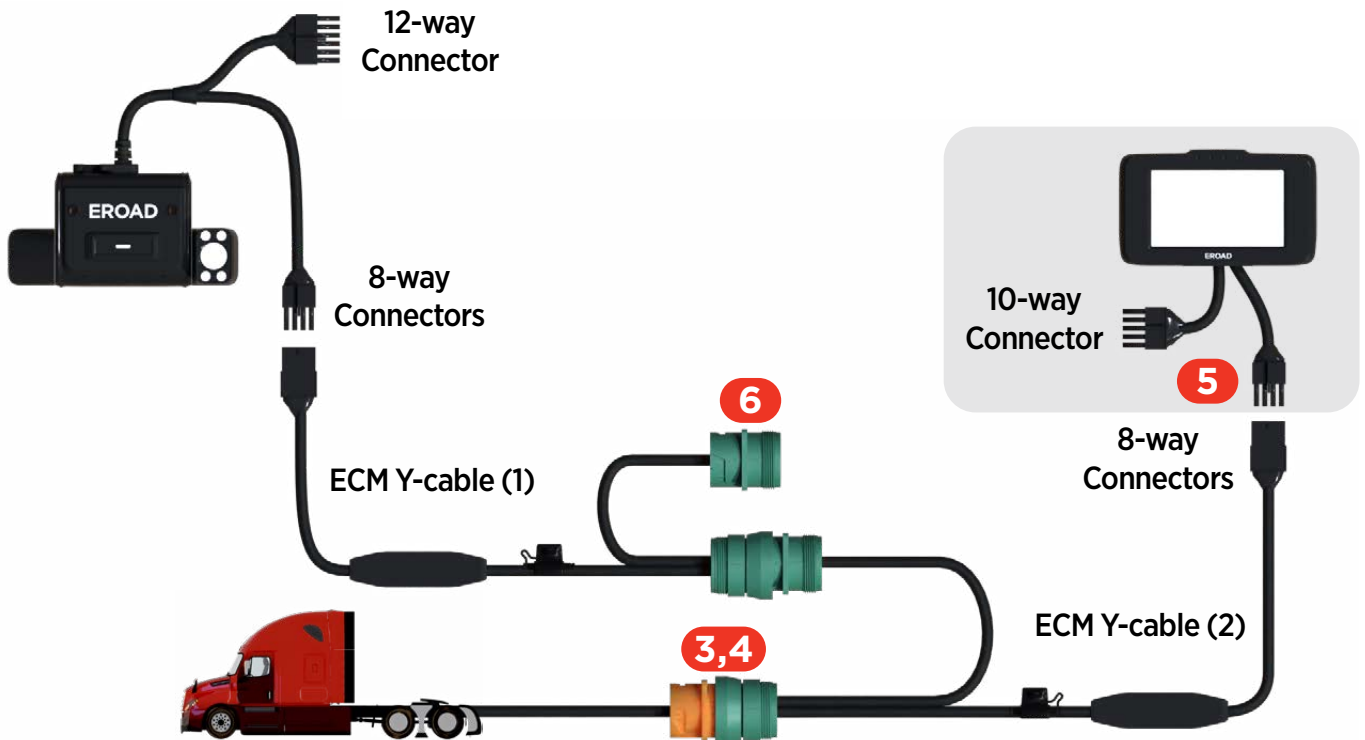

Remote Record Button install (Kit HR003106A) - Optional

- 1 Drill a 14mm (0.55in) diameter hole into a dashboard panel (or similar site within comfortable reach of the driver).
- 2 Connect the 12-way connector on the main camera power cable to the HR003106A Kit (12-to-2 wire loom). Secure with electrical tape.
- 3 Ensure the O-ring remains near the head of the button-thread while removing the nut and washer.
- 4 Thread the wires through the washer and nut.
- 5 Connect the 2-way connectors from the HR003106A Kit. Secure with electrical tape.
- 6 Tighten the nut and washer.
- 7 Use cable ties to coil and tie away any excess cable.

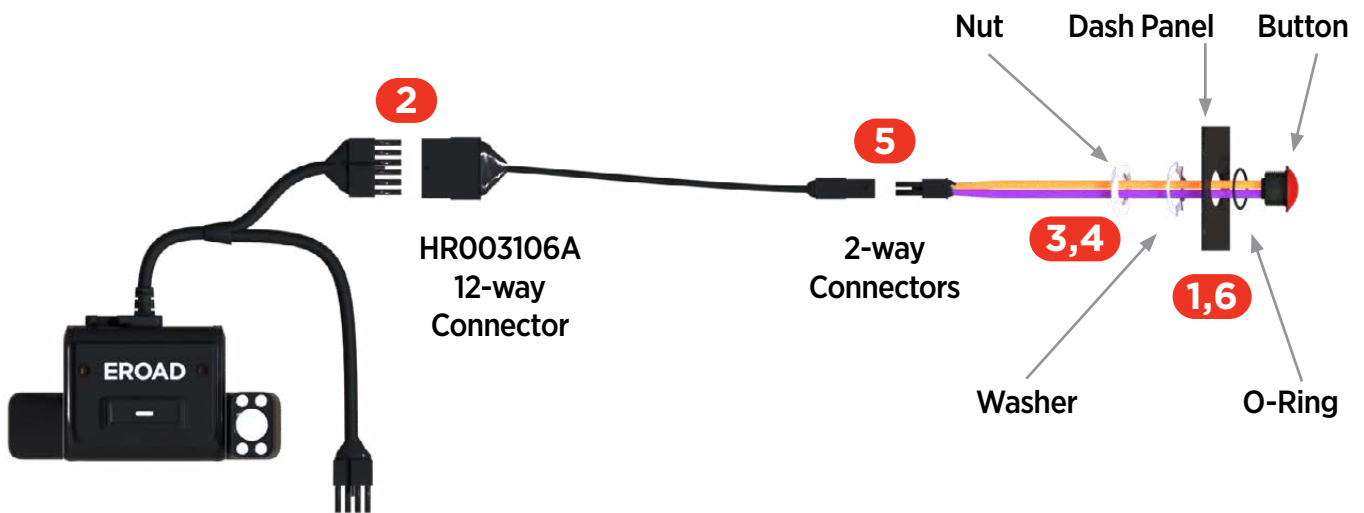

install.eroad.com : Configuring Clarity

IMPORTANT

These steps are required and Clarity will not operate correctly without them.

You need a mobile phone or tablet with a camera, an active Internet connection, and QR code scanning software (Apple devices can use the Photo application) to complete these steps.

- 1 Check that your dashcam mounting location and alignment meets regulatory requirements, local regulations and related company policies.
- 2 Remove the protective film from BOTH of the dashcam's lenses.
- 3 Scan the QR code (on the box in which the dashcam was packaged) with your mobile device to open the Install Wizard.

Note 16 If unable to use QR codes, go to: <https://install.eroad.com>.

Open a browser on your mobile device and type the dashcam's serial number into the displayed field. The serial number is printed on the packaging box after "S/N".

- 4 Follow the step-by-step procedure in the Install Wizard to ensure:
 - » the unit is provisioned correctly
 - » the cameras are aimed for optimal coverage, and;
 - » the Record button(s) operate correctly.

Note 17 When evaluating the road-facing camera please ensure that you have good visibility of the surrounding front hood of the vehicle and of the upcoming horizon. Best practice is to incorporate fender mirrors if possible.

- 5 Tighten BOTH the camera locking bolts.
- 6 Once the unit has passed its tests, attach the I/O port guard to the mounted unit using an Allen key. This screw secures the port guard and the mounting pad together with the main body.

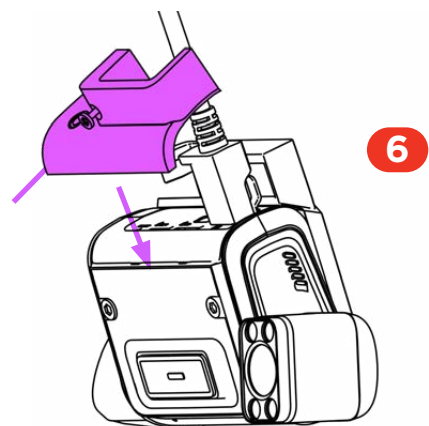
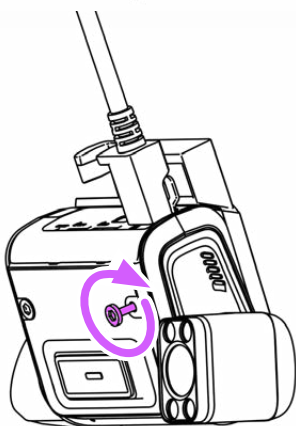
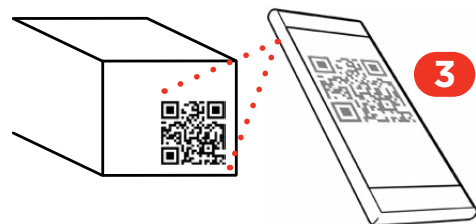
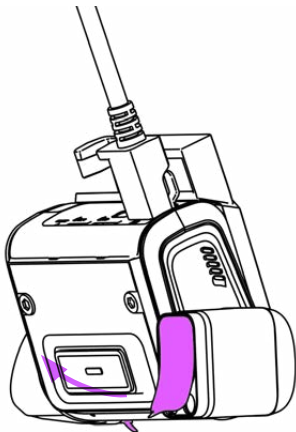

Photo confirmation

Photo document your work to assist in supporting work order documents and proof of regulatory compliance. Any digital camera may be used for 2 or 3 images per site, but images must:

- » Show the unit clearly, mounted in place, oriented appropriately.

- » Show connections and wiring secure and tidily managed. (The main dashcam cable should be hidden behind cab trim.)
- » Indicate the environment in which the device is installed (its position in the cab).

Note the vehicle make/model for future reference.

NOTE

Photos are evidence of a compliant install. They protect EROAD and the Installer's liability if a future 3rd party alteration or incident affects compliance integrity.

General Purpose In/Out (GPIO)

GPIO looms are sets of wires with specific purposes: power or signals. They may be used to route data from, or power to, a variety of sensors for seatbelts, brakes, indicators, thermostats, windshield wipers, etc.

Please review the pin-out tables provided carefully before attempting to wire up a loom.

A full pin-out appears with every instruction set, **but notable GPIO inputs include the BROWN and GREY wires.**

The BLUE wire is the only GPIO output.

The overmold diode board takes the two +ve power conductors and two ground connections to control the current direction.

About Engine Control Modules (ECMs)

The ECM is the hub of a network of controllers (sensors, winches, power modules, etc) operating over a Controller Area Network, or CAN.

The ECM Y-cable lets you to add more controllers to your CAN by daisy-chaining them together.

ECM connectivity isn't essential for Clarity to operate. Power can be sourced through wiring the appropriate loom pin-out to 12 V DC power.

Safety & Best Practices

CAUTION

If installing this equipment on an unfamiliar vehicle, consult the vehicle's manufacturer specifications beforehand.

- » Before installation, check that other safety-relevant equipment is working properly and report any issues immediately.
- » EROAD expects installers and contractors to understand and follow all relevant health and safety regulatory requirements, as well as customer and relevant third party requirements.
- » Wear appropriate Personal Protective Equipment (PPE) for the install risk and customer requirements. Appropriate PPE may include safety glasses, safety shoes, work gloves, hard hat, high visibility vest, sun cream, sun hat and/or coveralls.
- » Avoid positioning EROAD equipment in locations that could impede normal operation or cause injury to people. This includes potential head strike zones on the windshield or dashboard, airbag deployment locations, seatbelts, and other safety-relevant devices. The dashcam must be mounted outside the driver's sightlines of the road, highway signs, and signals.
- » Avoid running cables close to heat sources, sharp edges, obstacles or safety-relevant devices.
- » After installation, check that all other safety-relevant equipment continues to work properly. Report any issues immediately.
- » Before working under or around suspended equipment – held aloft with slings, hoists, or jacks – ensure the equipment is secured to prevent collapse or falls.
- » While EROAD hardware is comprehensively tested against corrosion and ingress, they are not invulnerable to water, fire or impact damage. Do not subject EROAD units to extreme heat, water force or intense forces.
- » Protect EROAD devices from extreme temperatures. Operating temperatures for the equipment related to this guide are found in the specifications page.
- » The EROAD Clarity Dashcam installation pack includes a sticker to notify vehicle occupants that the vehicle is equipped with an audio and video recording device. This should be attached to the inside of the vehicle and be visible to all occupants.

Specifications

Dimensions	122W x 76H x 38.5D mm 4.8W x 3.0H x 1.5D in
-------------------	--

Weight	157.7 g
---------------	---------

Power	9–32 V DC
--------------	-----------

Op. Temp.	-20°C to +60°C
------------------	----------------

Ingress	IP41
----------------	------

EROAD Technical Support

North America 1-855-503-7623 support@eroad.com

Australia 1800 437 623 support@eroad.com.au

New Zealand 0800 437 623 support@eroad.co.nz

