



# Clarity Edge install guide for Power Module 1.0 systems



This document covers the installation of the Clarity Edge 1.0 system, including the optional Fatigue camera, and optional Seatshaker.

The 1.0 system includes the Power module v1.0, and the Seatshaker's Datahub.

## Technical support

<b>North America</b>	1-855-503-7623	<a href="mailto:support@eroad.com">support@eroad.com</a>
<b>Australia</b>	1800 437 623	<a href="mailto:support@eroad.com.au">support@eroad.com.au</a>
<b>New Zealand</b>	0800 437 623	<a href="mailto:support@eroad.co.nz">support@eroad.co.nz</a>



FCC ID: 2AM6L-ADP2



## Contents

- [Clarity Edge install guide for Power Module 1.0 systems](#)
- [Contents](#)
- [Overview & Parts](#)
- [Pre-install](#)
- [Vehicle power \(standard\) install](#)
- [OBDII install](#)
- [Fatigue camera install](#)
- [Seatshaker install](#)
- [Location metrics](#)
- [Using the Clarity Edge installer app](#)
- [Troubleshooting](#)
- [Inserting the MiniSD cards](#)
  - [Health & Safety](#)
  - [Legal disclaimer](#)
- [Specifications](#)



## Overview & Parts

### Overview

To work correctly, **EROAD Clarity Edge** (“the unit”) must be mounted and calibrated, but mounting the unit and its optional accessories can affect the calibration. To combat this potential ‘chicken and egg’ scenario, EROAD mandates this general workflow:

1. If applicable, load approved miniSD card(s) and SIM cards and remove the protective lens films.
2. Mount the unit in the position indicated by the following instructions.
3. Roughly position optional accessories into their likely positions, and connect them together.
4. Connect the system to power, and calibrate the system’s components with the Clarity Edge Installer app. The app generates video feedback to see camera views, so you may firm up the position of optional cameras.
5. Troubleshoot where necessary.
6. Tidy cables and cab; photo-document the install.

### Parts

1



**Dashcam**

2



**Standard power cable**

3



**Fused power loom**

4



**Allen key**

5



**Mount**

6



**Mount bolt**

7



**Crowbar**

8



**Desiccant**

9



**IPA wipe**



*IPC cable clamp*



- Regulatory card
- Window sticker
- Lens cover

## **Optional extras**

- Standard-to-OBDII connector kit (comes with Y-splitter to allow additional OBD device)
- Fatigue Camera kit (Optional)
- Remote button kit (Optional)



## Pre-install

**!** EROAD windshield mounts come with a single-use approved adhesive tape that should not be altered, removed, or otherwise compromised. **New glass requires new mounts**, to ensure the equipment performs to specification.

**Recycling old mounts with new adhesive tape is not supported, and risks endangering drivers and equipment.**

**!** **Deviations from these instructions may result in a re-installation callout at the Installer's expense.**

Following this guide means the mounting location will comply with local regulations.

## Mounting Clarity Edge

The Clarity Edge unit comes with the Standard mount bracket. This bracket allows for up to 80° of tilt in common raked windshields.

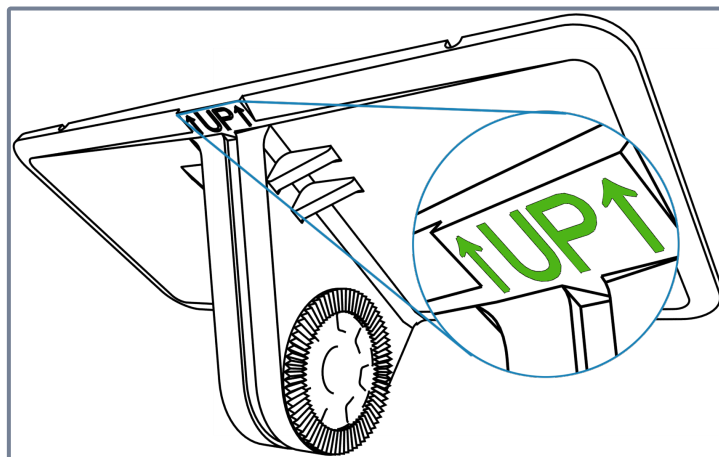

## Site position

The optimum site position is:

- **HORIZONTAL:** Within 50 mm (2 in) of the windshield's midline. (Within 150 mm (6 in) is supported.) On flat ground, installers could use a spirit level or reliable digital app for alignment assistance.
- **VERTICAL:** In a zone approximately 20 cm (8 in) below the topmost sweep-edge of the windshield wipers or windshield tint visor, whichever is lowest, but above the eyeline of a tall driver.
- **PROXIMITY:** Ideally, within 116 cm (46 in) from the driver's face.

Avoid installing other electronic devices around the unit, like intelligent rearview mirrors or electronic tags.

## Cable routing

EROAD recommends following standard OEM cable routing practices. Cable tie the unit's cable at regular intervals.

- Tuck all cabling out of sight along the windshield, and/or behind the roof and A-Pillar trim.
- Extra cable is **tidied securely behind the dash**.
- Extra Fatigue camera cable should be **tidied securely behind the roof trim**, close to the Clarity Edge camera.



**i** In some vehicles (eg. late model Scania's) there is a cable-tidy shroud for use within the passenger-side A-Pillar.

The basic route of the unit's loom runs from the **mounting location, under the roof and passenger-side A-pillar trim, to behind the dash**. The illustrations earlier also show the basic cable routing of the optional **fatigue camera, up behind the opposite A-pillar trim to the unit**, and the optional button for remote triggering a recorded clip, mounted on a dash blank.

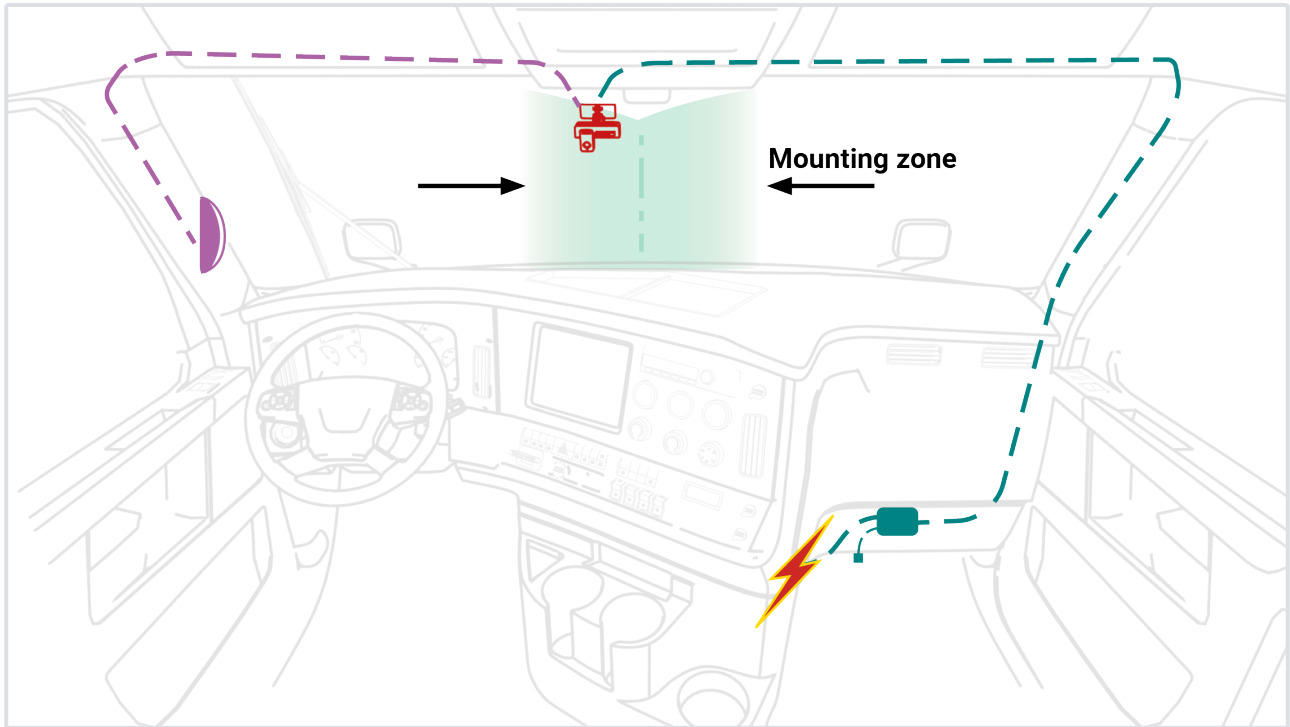

*Left-hand drive cable routing and optimal positioning*

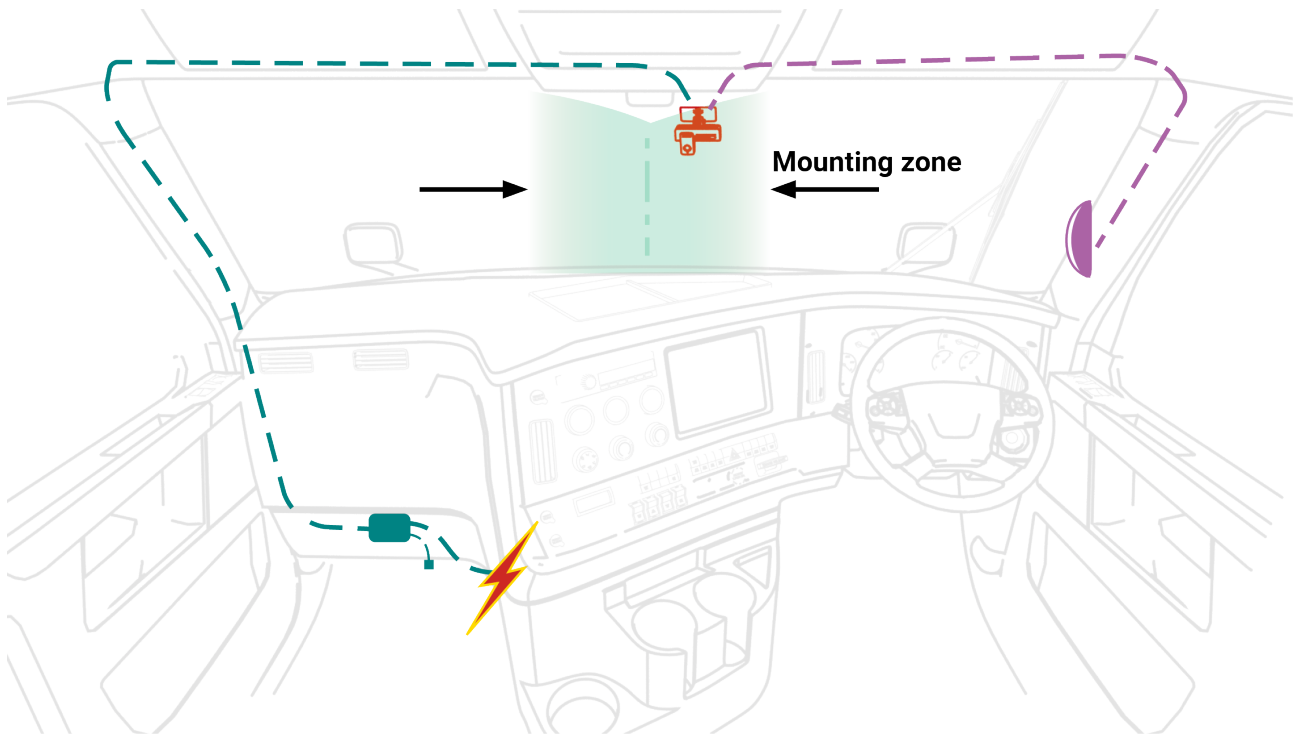

*Right-hand drive cable routing and optimal positioning*

## Mounting the Clarity Edge to the windshield

1. Clean the intended installation area with the IPA wipe.
2. Rewipe with a clean cloth, to remove any IPA residue.
3. Remove the 3M adhesive backing tape.
4. Align the long 'UP' edge horizontally, and press the bracket into the windshield for 10s such that no air bubbles are trapped between the windshield and bracket.
5. Connect the unit to the bracket with the front side facing inward (teeth on the right side of the bracket engaged with those on the right inner side of the unit).
6. Orient the unit so its top is level. Tighten the bracket stud with a PH2 Phillips screwdriver.



## Vehicle power (standard) install

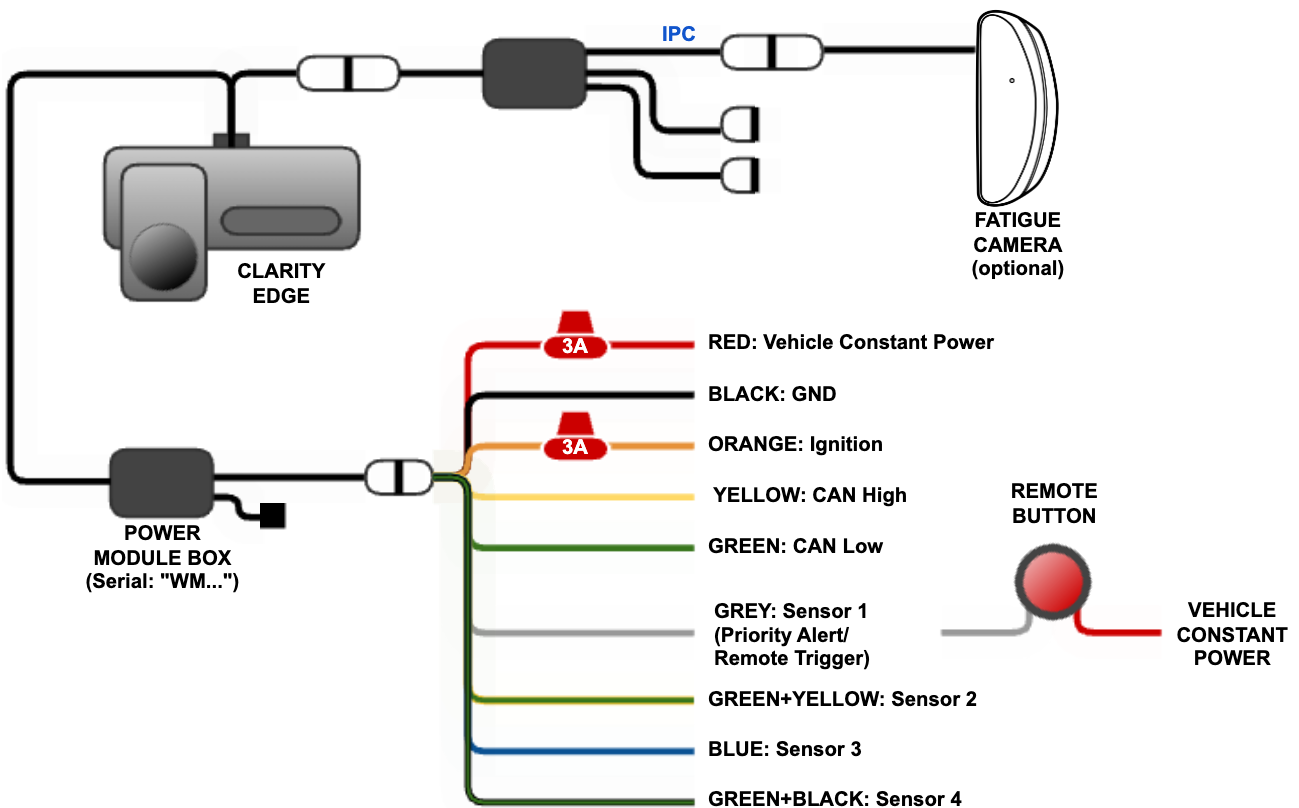

*Standard Power/Ground/Ignition install, with other GPIOs listed (Remote button optional)*

1. Connect the unit to the standard power supply cable.
2. Run the cable as illustrated behind the dash. Avoid loops and pinches in the cable.
3. Connect the fused power loom to the standard cable.
4. Connect **Power** (fused), **ACC** (Ignition, fused) and **GND** to the corresponding correct vehicle connection points for the vehicle.
5. Use the EROAD recommended connection method of solder, tape & cable tie.



**The power Module Box MUST be firmly mounted in place via cable ties/ double sided tape.** secure it clear of any excessive shake or vibration locations (loudspeakers, engine, etc)



The power Module Box has a built-in turning-on/off control functionality.



## Standard power cable pinouts

Signal	Color	10-pin DIN male
ACC	Orange	6 (3A fused)
CAN-L	Yellow	1
CAN-H	Green	2
Sensor IN3	Blue	8
Sensor IN2	Green-Yellow	7
Sensor IN1	Grey	5 (Remote Trigger)
Sensor IN4	Green-Black	9
Power	Red	3 (3A fused)
GND	Black	10



## OBDII install

**i** If the OBDII port is already occupied, perform a standard installation.

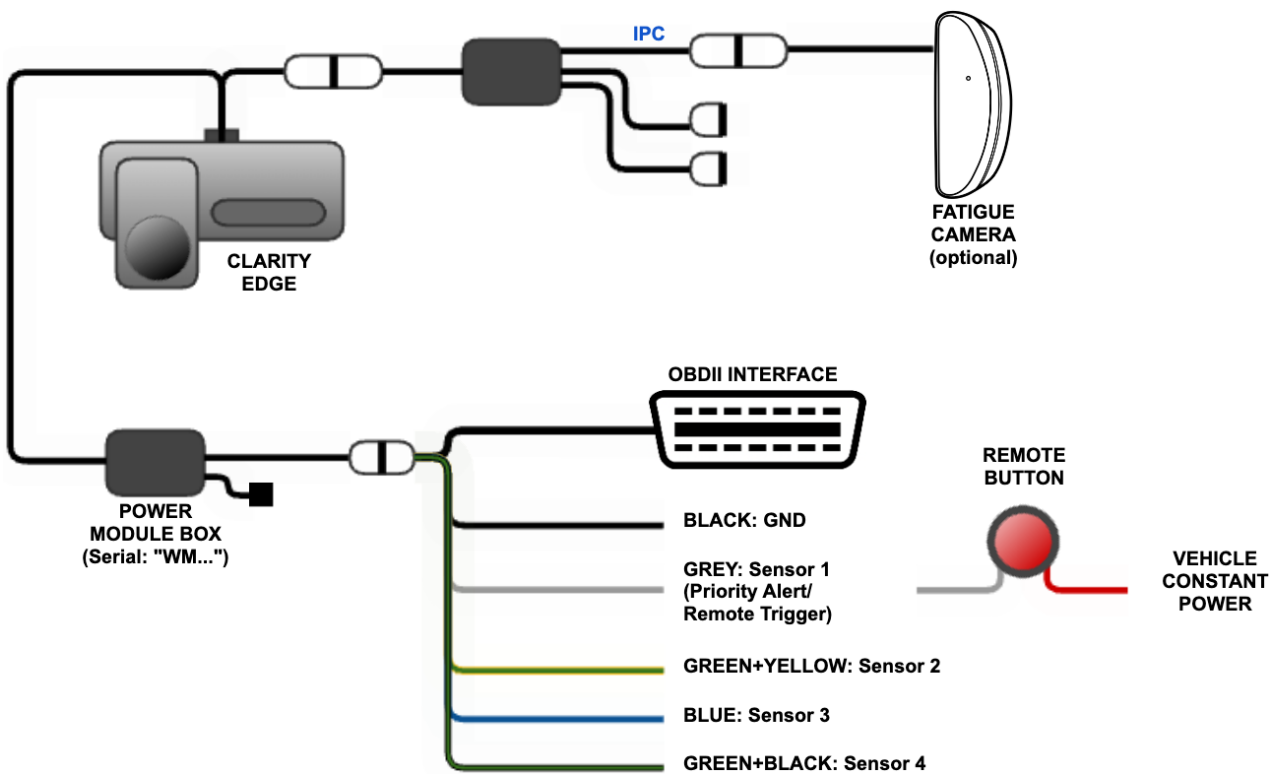

*OBDII install (Remote button optional)*

1. Attach the OBDII harness to the unit loom, and plug the OBDII connector into the vehicle's port.

- !** The power module box **MUST** be firmly mounted in place via cable ties/ double sided tape. It needs to be kept clear of any locations with excessive shake or vibration (loudspeakers, engine, etc).
- The power module box has a built-in turning-on/off control functionality).



## OBDII cable pinouts

Signal	Color
GND	Black
Sensor IN1	Grey (Remote Trigger)
Sensor IN2	Blue
Sensor IN3	Green-Yellow
Sensor IN4	Green-Black



## Fatigue camera install

### Video

**Fatigue Camera install video** - <https://vimeo.com/955628260/5b4d861ea3>

Each Fatigue camera will come with the ordered mounting option: A-Pillar, or Windshield.

**!** If the customer has ordered mounts that are inappropriate or dangerous for Fatigue camera installation, inform the customer before proceeding.

**✘** Check the vehicle for side-curtain airbags. If present, the Fatigue camera **MUST NOT** be fitted to the A-Pillar frame or trim.

### A-Pillar mount

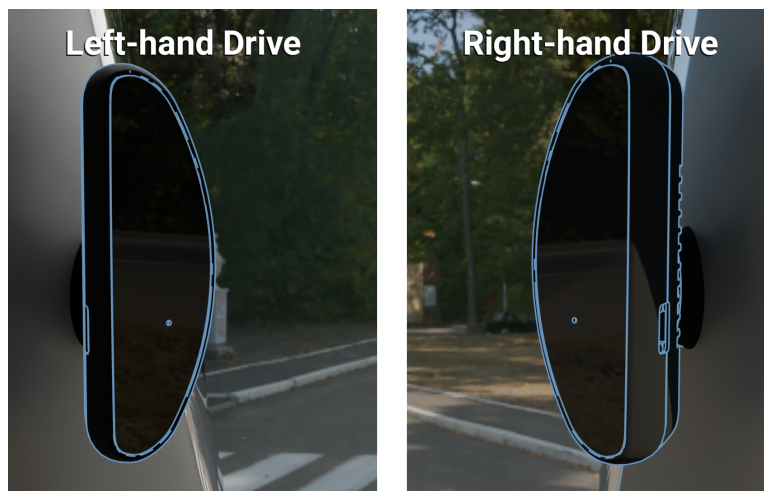

*Fatigue camera*

The previous video link showed how to install, including drilling 2 holes for the mount. Each location has a specific mount. If the correct mount is missing, inform the customer.

### Windshield mount

1. **Ensure you have used the Clarity Edge Installer to determine the best position, and use a black marker to mark that location. That location must allow 100% adhesion of the double sided tape on the base.**



*Windshield mount*



2. **Ensure two grub screws are tightened fully, one as pictured above and one on the rear of the mount.**
3. Connect the Fatigue camera cable to the IPC connection of the 3-way extension cable.
4. You should be able to tuck the cable under the A-Pillar trim without having to drill an extra hole.
5. Tuck and fit the cable behind the A-Pillar, run it up and along the cab roof trim, to the Clarity Edge unit.
6. Clean the intended installation area with the IPA wipe.
7. Rewipe with a clean cloth, to remove any IPA residue.
8. Remove the adhesive tape backing from the mount.
9. Press the bracket into the windshield for 10s such that no air bubbles are trapped between the windshield and bracket. Replace the ENTIRE MOUNT of the Fatigue camera. **Do NOT attempt to replace just the adhesive tape.**



## Mounting the Fatigue camera

1. The Fatigue camera is D-shaped. The flat face of the 'D' faces the A-Pillar (or dash, if dash-mounted); Curved side generally faces mid-windshield.
2. Distance: 50-100cm from common Driver-position face.
3. Vertical Height: above steering wheel; no more than 30 cm vertical below driver's chin.
4. Angle: Tilt the flat, reflective front of camera to Driver-position face (should see your own reflection when in Driver-position).
5. After mounting, use the Installation App's Live View assist to ensure the camera is:
  - a. free from blue protective lens film
  - b. centered on Driver-position face
  - c. mounted BELOW Driver-position face (red dotted line)



- d. angled, looking UP to Driver-position face (blue arrow)
  - e. lower edge of frame includes view of Driver chest
  - f. clear of visual obstructions (inc. steering wheel, levers, etc)
  - g. clean of fingerprints, oil, etc.
6. **Connect the Fatigue camera cable to:**
  - a. **Power Module V1.0 system:**
    - i. the IPC connection of the IPC loom.
    - ii. Thread the other end of the IPC loom through the Fatigue camera cable clamp, such that the white dot faces through the gap, and near the eye end.
  - b. **PowerboxMAX V1.0 system (Multicam):**
    - i. the IPC cable at the back of the Powerbox Max V1.0
    - ii. Thread the PowerboxMAX V1.0 LAN cable through the Fatigue camera cable clamp, such that the white dot faces through the gap, and near the eye end.

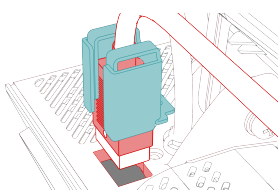

*IPC/LAN connection port; cable clamp (Green)*



7. Assuming A-Pillar installation is OK, you should be able to tuck the cable under the A-Pillar trim, with no need for an additional drill hole. Run the cable behind the A-Pillar, along the cab roof trim, to the Clarity Edge.
8. Thread the IPC camera cable through the Fatigue camera cable clamp, such that the white dot faces through the gap, and near the eye end.
9. Using the screw near the Clarity Edge's main cable exit, screw in the IPC cable clamp.



You can rough-adjust the camera to face the driver's head restraint (headrest). The Clarity Installer app will provide more accurate alignment.



## Seatshaker install

### Pre-installation notes

1. The EROAD Seatshaker requires the EROAD Fatigue Camera for operation.
2. When installing the Seatshaker as an independent job item after a Clarity Edge install, Installers are still required to run the Clarity Edge Installer app to ensure connectivity and registration issues are tested and documented.

## Parts



*Seatshaker*



*Datahub + Edge Extension cable*



*Seatshaker Powerbox+loom*



*Seatshaker power*



**1**  
*1. Datahub sensor loom*



**2**  
*2. Datahub power loom*





5. Solder then heat-shrink/tape the following connections (wires are in the format **COLOR / 'LABEL'**):
  - a. Powerbox loom **ORANGE / 'SEAT CNTL'** to Datahub sensor loom **YELLOW-WHITE / 'SENSOR OUT 1'**
  - b. Powerbox loom **RED FUSED / 'DC IN+'** to vehicle **CONSTANT POWER (fused 15 A)**
  - c. Powerbox loom **YELLOW / 'ACC'** to vehicle **IGNITION**
  - d. Powerbox loom **BLACK / 'DC IN-'** to vehicle **GND**
  - e. Powerbox loom **BLACK / 'GND'** to vehicle **GND**
  - f. Datahub loom **RED / 'VIN'** to vehicle **CONSTANT POWER (fused, 3 A)**
  - g. Datahub loom **ORANGE / 'IGN'** to vehicle **IGNITION (fused, 3 A)**
  - h. Datahub loom **BLACK / 'GND'** to vehicle **GND**
  - i. Remote button (optional): Button **ORANGE** wire to Datahub power loom **GREY / 'SENSOR IN1'**; Button **RED** to Vehicle **CONSTANT POWER**
6. Plug looms and cables into their appropriate sockets.
7. Wrap and tidy unused wires and excess cabling.



*Seatshaker mounted to chair's steel strut bar, ABOVE the airseat.*

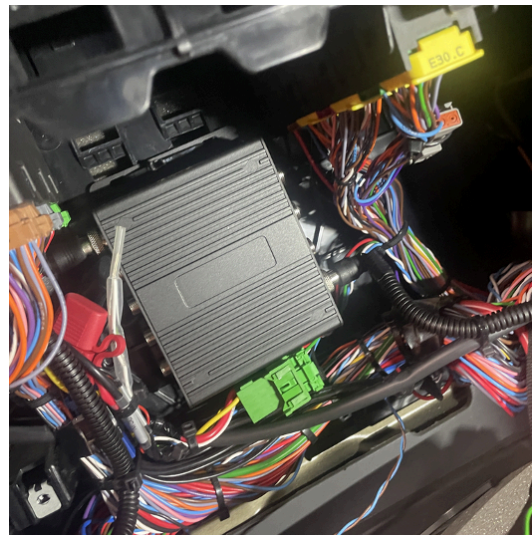

*Powerbox for Seatshaker secured under the dash.*



## Location metrics

To calibrate the road-facing camera, **you need to first accurately measure** the following distances from the road-facing camera lens position. Enter these measurements in the Clarity Installer app fields.

To calibrate the road-facing camera, **you need to first accurately measure** the following distances from the road-facing camera lens position. Enter these measurements in the Clarity Installer app fields.

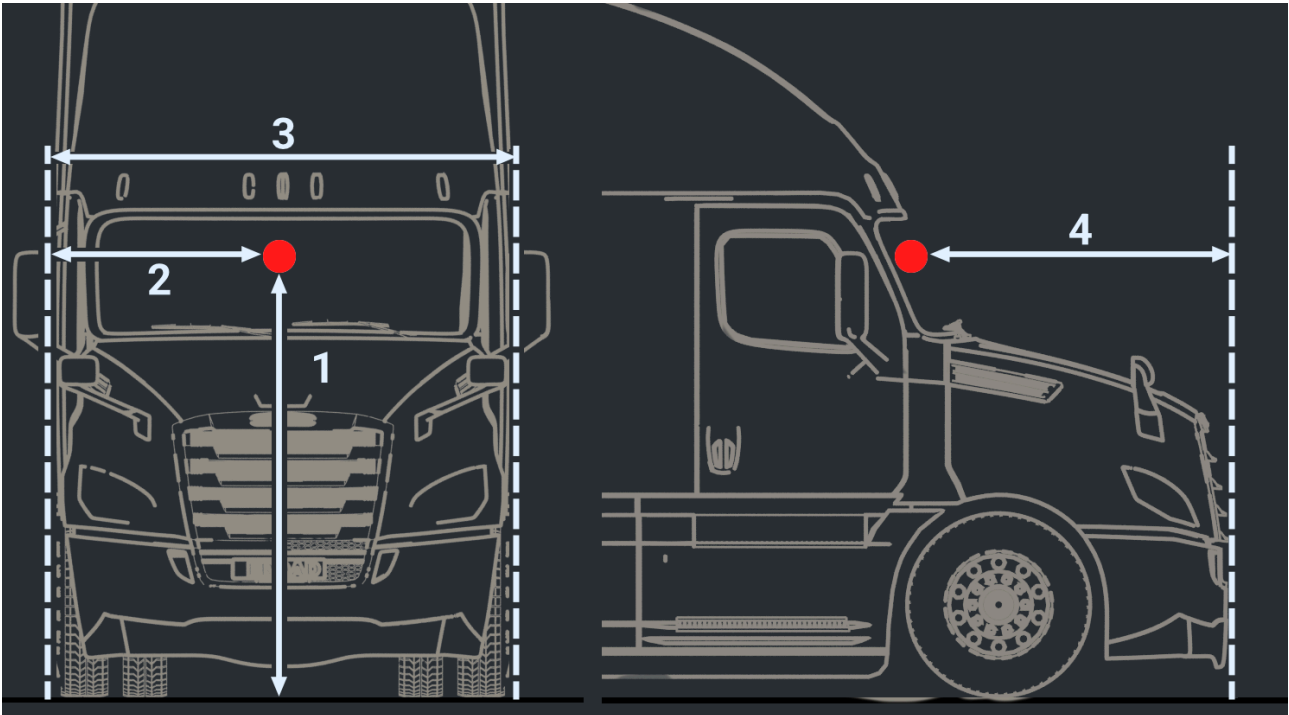

Height to Camera (1); Distance from camera lens to left of truck excluding wing mirrors (2); Width of truck, excluding wing mirrors (3); Distance from frontmost bumper/grill to camera (4)

1. **HEIGHT:** the vertical height (accurate to cm/inch) from the ground to the lens with a tower ruler or tape. This is the ADAS lens installation height.
2. **LEFT MARGIN:** the horizontal distance from the lens to the outermost edge of the LEFT tire.



LEFT is left from viewing the vehicle from the **outside**, front. Always. It doesn't matter which side the steering column is: left is from the outside front.

**Side mirrors are NOT considered in measuring width or margin**, even if they extend past the main body sides.

3. **FRONT-END WIDTH:** the distance between the outermost edges of opposite tires. (Side mirrors are NOT appropriate points, even if they extend beyond the cab width.)
4. **FRONT LENGTH:** the horizontal distance from the camera lens to the frontmost point of the vehicle.



**Accurate measurements are crucial, or the unit could generate false lane departure warnings or similar.**



## Using the Clarity Edge installer app

Download and install **Clarity Edge** installer from the Apple store or Google Play.

- i** There are several apps on the Apple Store or GooglePlay with the words 'Clarity' or 'Edge' in their titles. EROAD mobile apps feature simple red/white icons, and are made by EROAD.

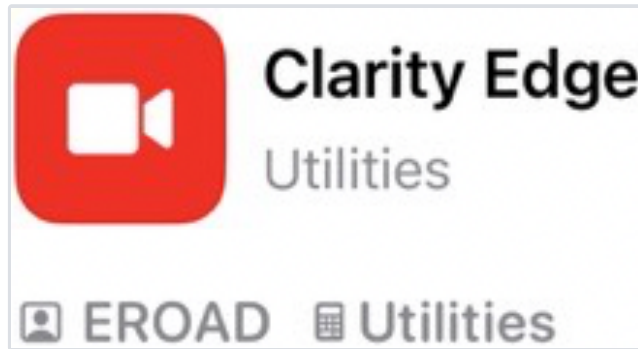

*Click to download to your iOS device*



*Click to download to your Android device*



## Configuring the Clarity Edge

- If you haven't already, remove the blue protective film from both camera lenses.
- Assemble the unit's WiFi address, QR codes, or other reference material ready to enter.

When powered, each unit generates its own WiFi network. You will connect to this network on your device for setup and calibration.



There are minor variations between the iOS and Android versions of Clarity Edge Installer, but they do not affect the process.

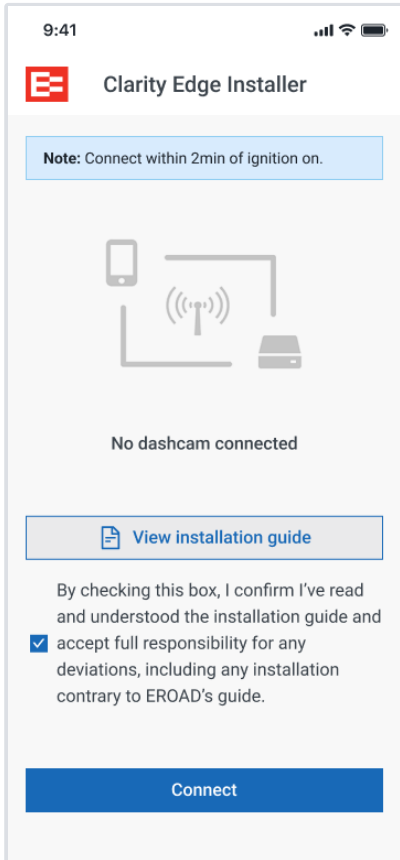

1. The start screen requires you confirm you have read and understood the process found in this guide.

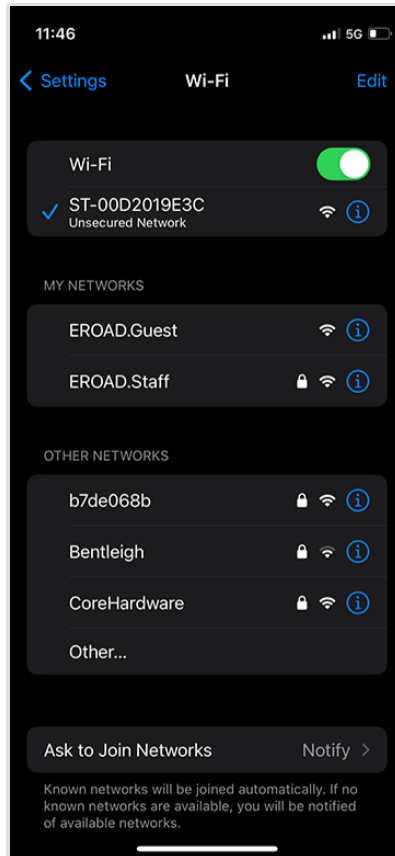

2. Select the unit's WiFi ID. This is found on the Clarity Edge sticker.

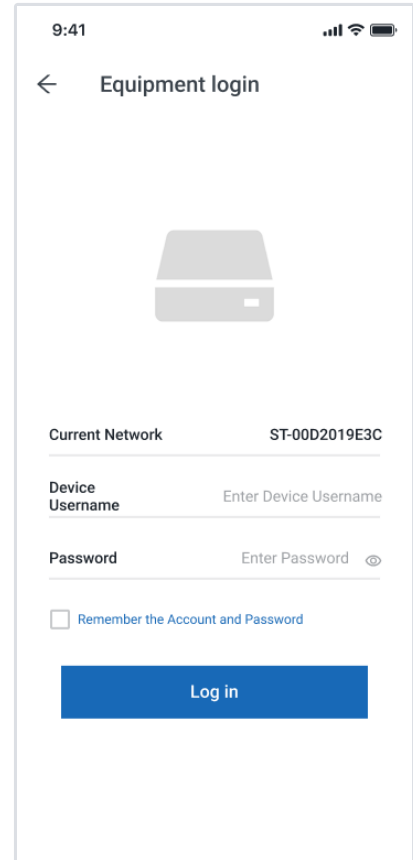

3. Contact your EROAD representative for the Device Username and Password.

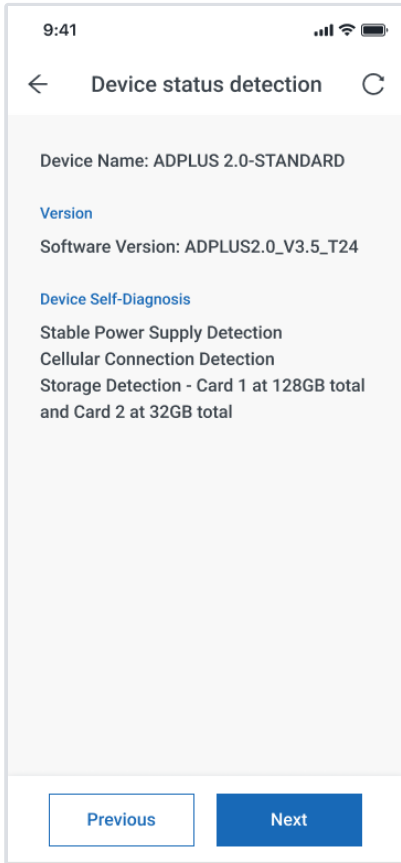

4. Review and confirm connection statuses

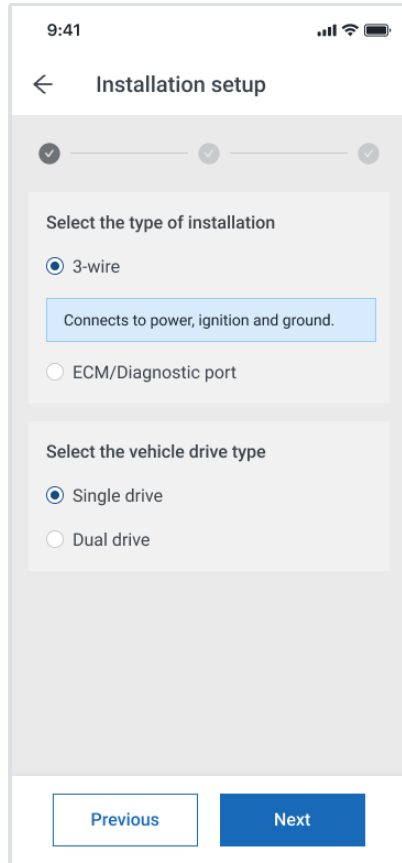

5. A 3-wire single drive install is common; Dual drive for twin steering setups.

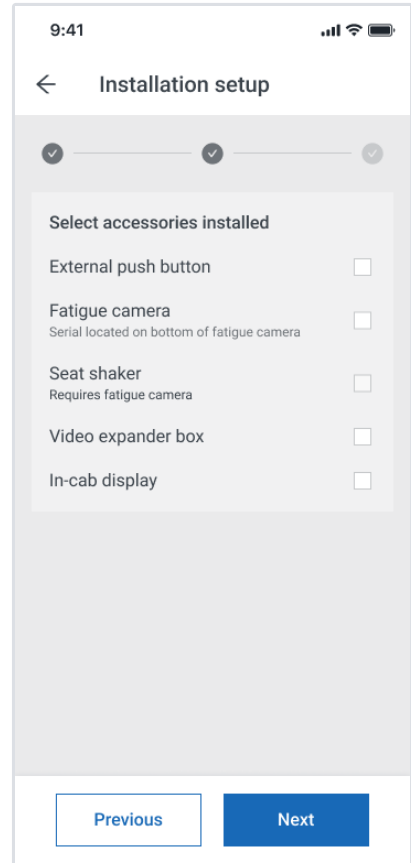

6. Accessories. For Edge + Fatigue + Seatshaker installs, the expander and display options are not required.

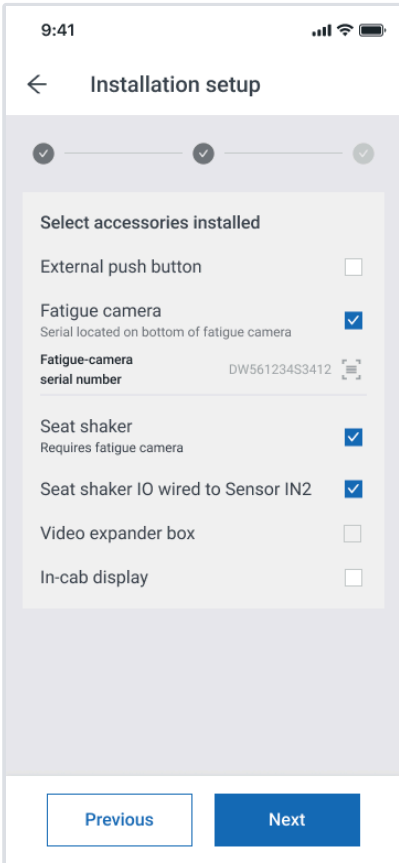

7. Select the gear to be installed. Selecting 'Fatigue' enables the serial# scanner for its barcode. The Shaker IO wire will be connected to the Powerbox v1.1 SENSOR IN2 wire.

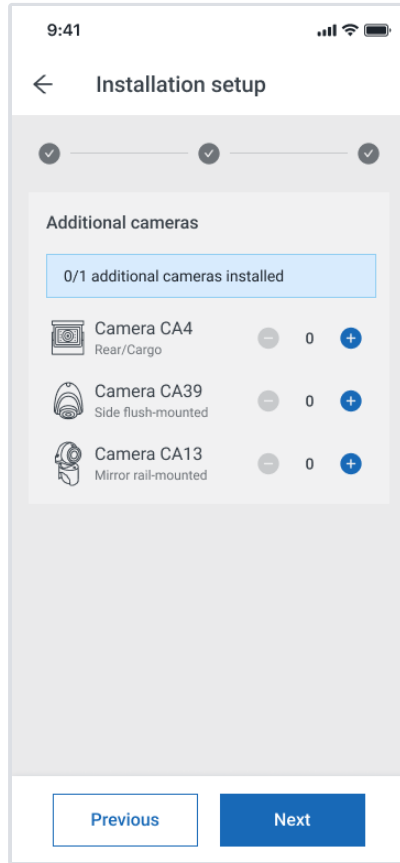

8. Unless there is an additional camera to install, this screen may be skipped.

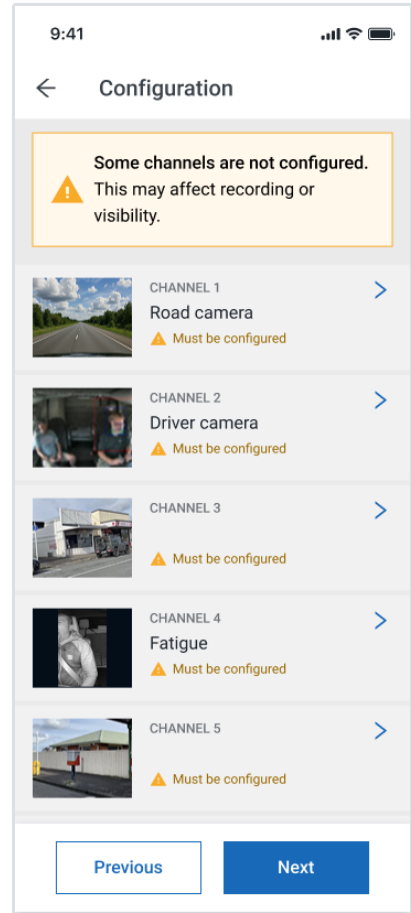

9. Go through each camera to configure. (For Dual Drive, Channel 4 will have 2 Fatigue cameras to configure.)

Channel 4 must ALWAYS be the Fatigue camera, if installed.

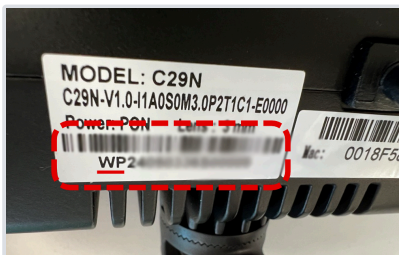

Fatigue camera serial#.

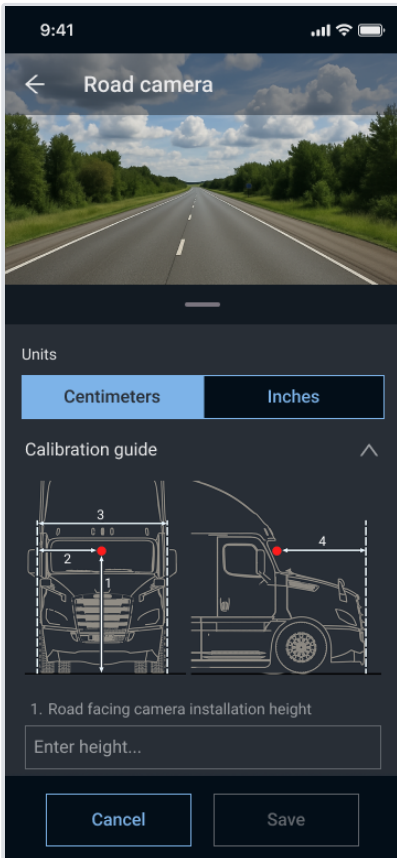

10. Road cam config. Measurements must be within 2 cm precision to mitigate false lane departure alerts. Camera view must be level with the horizon.

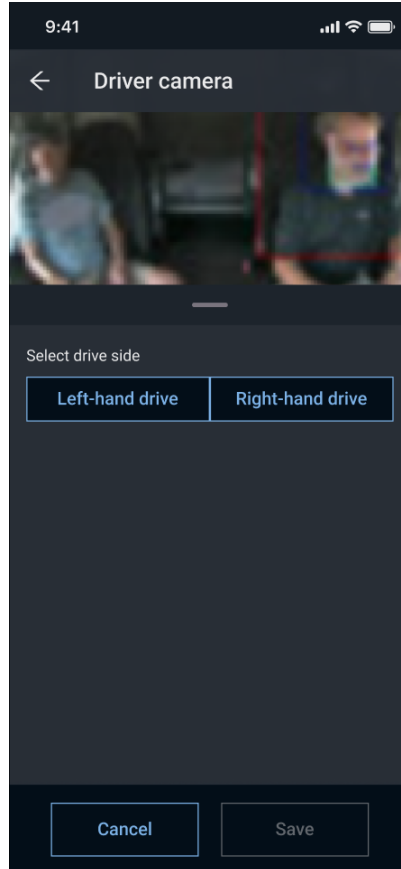

11. Driver cam config (Single drive only). This sets US/ ANZ driving sides. (Dual Drive installs will skip this screen.)

You may need to adjust the tilt of the Clarity Edge to see the driver-position properly.

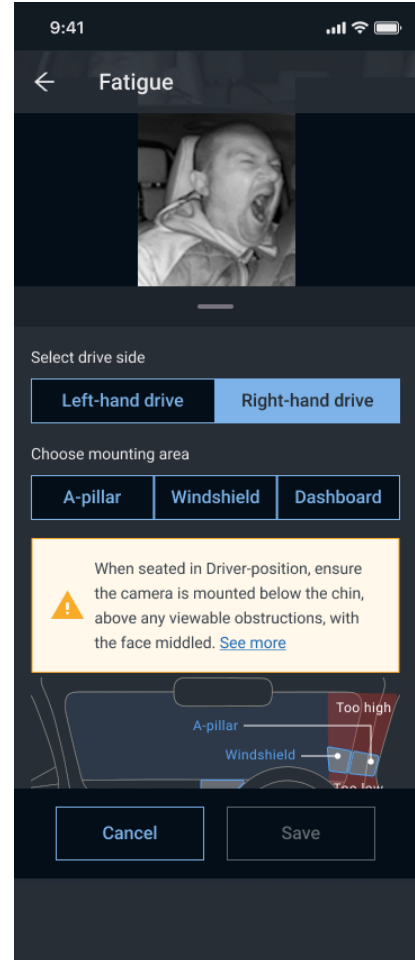

12. Fatigue cam config (Single drive selected). If installing Dual fatigue, this screen will have a second positioning option and a mirrored positioning diagram. 'See more...' provides a side-on diagram and detailed descriptions to position the Fatigue camera.

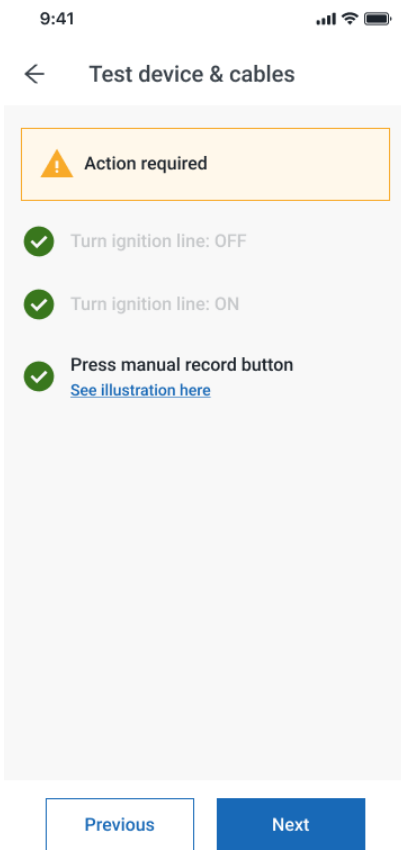

13. Testing. The app will lead you through a multi-staged connectivity test, with recommendations if a test fails.

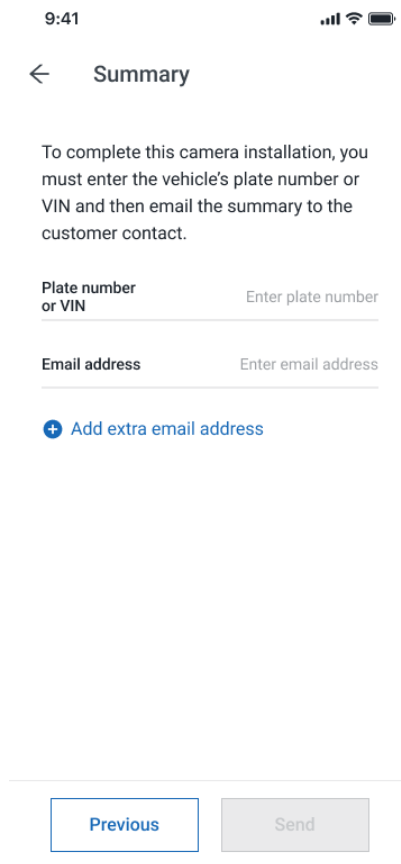

14. Enter the vehicle's VIN and customer email.

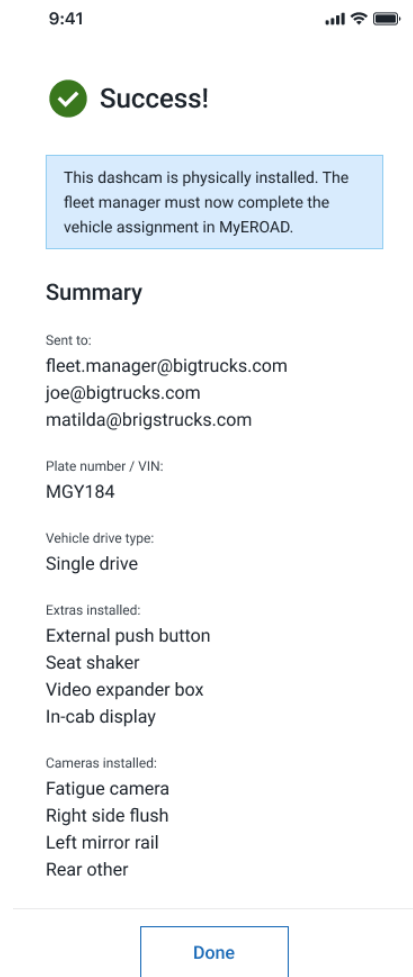







15. Success summary. Done.



## Troubleshooting

### LED indicators

During normal operation all the unit's status lights are off, except the Power icon (Green).

<p><b>Power</b></p> 	<p><b>Off:</b> The unit is not powered on  <b>Green:</b> The unit is powered normally</p>
<p><b>Alarm</b></p> 	<p><b>Off:</b> The unit is operating properly  <b>Red flashes x3:</b> The unit generates an alarm                  The fault indicator of the OBD port blinks twice every second until the fault is removed</p>
<p><b>GPS</b></p> 	<p><b>Off:</b> GPS is operating properly  <b>Red:</b> The unit is out of coverage; module fault  <b>Red, flashing:</b> The unit has poor coverage</p>
<p><b>Network</b></p> 	<p><b>Off:</b> The unit is connected to the server properly  <b>Red:</b> The unit is connecting intermittently, or through unverified hotspots  <b>Red, flashing:</b> The unit is in Flight mode (operating properly, but offline)</p>
<p><b>WiFi</b></p> 	<p><b>Off:</b> No WiFi connection.  <b>Green:</b> Ready for WiFi connection.</p> <div style="border: 1px solid green; padding: 5px; margin-top: 10px;"> <p> WiFi connection is only used for unit configuration.</p> </div>



<p><b>Record</b></p> 	<p><b>Off:</b> No triggered recording in operation.</p> <p><b>Red:</b> Recording/ SD Card error: unable to read/write.</p>
--	--

## Hardware faults

### Device startup failure

- Check that the power cable is well connected, the fuse intact and is fully inserted.
- According to the power supply logic designed for the system, when the device is powered by OBD, it is powered when the vehicle is moving (G-sensor acceleration value > 10 g). If the OBD is installed under normal power supply, shake the power box slightly.

### Device Networking Failure after Startup

Make sure that the SIM card is inserted before device startup. If it is inserted after device startup, please power off and restart the device.

- Check whether the SIM card is installed correctly.
- Check whether the network signal at the current position is good.
- Check the condition of the SIM card.

### Device Recording Failure after Startup

- Make sure that the SD card is inserted before unit startup. If it is inserted after unit startup, please power off and restart the unit.
- Check whether the SD card is installed correctly.
- After the SD card is inserted into the unit, format it before use.



## Inserting the MiniSD cards

Check the label on your Clarity Edge to determine SD Card orientation.

### AD Plus 2.0

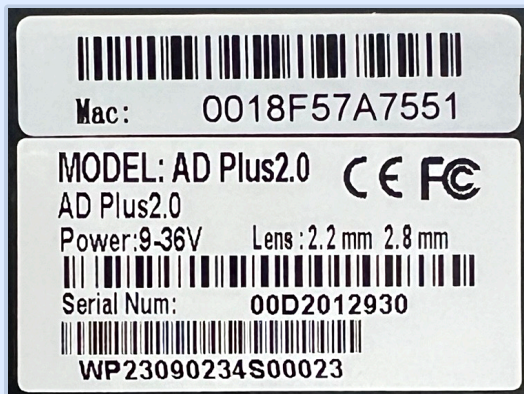

*"AD Plus2.0" has nothing beside it*



*Gold contacts face **TOWARDS** each other.*

### AD Plus 2.0 (V1.1)

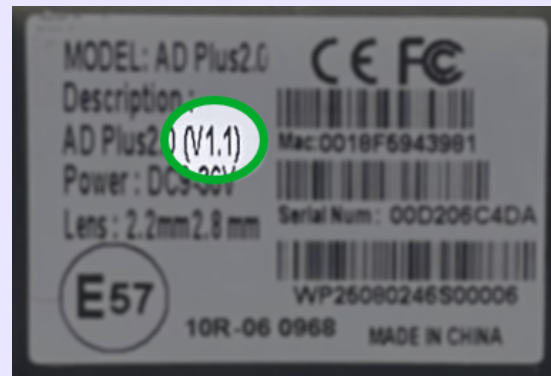

*"AD Plus2.0" has "V1.1" beside it*

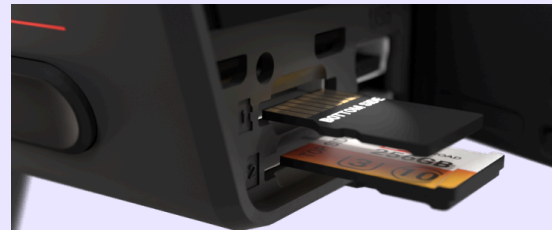

*Gold contacts face **AWAY FROM** each other.*

## Instructions

1. Ignition OFF.
2. Using a T6 Torx driver, unscrew side Port cover and open.
3. Replace with the card(s) supplied in this pack. Push in completely to click in place.
4. Close cover; re-tighten screw.

Ignition on; check Clarity Edge Camera icon:

- If **RED**, re-check that MiniSD cards are seated correctly.
- If **RED** for more than 1 minute, contact EROAD Support – email & phone contacts overleaf.



## Photo verification

Installers are encouraged to photo-document their work – through dedicated apps like vWork, bespoke configuration apps, or general cameras – to assist in supporting work order documents. Any digital camera may be used for 2 or 3 images per site, but images must:

- Show the device clearly, mounted in place, oriented appropriately.
- Show connections and wiring secure and tidily managed.
- Indicate the environment in which the device is installed (its position in the cab, or on the asset).
- You may also wish to note the vehicle make/model for future reference.



**Photos are evidence of a compliant install.** They protect EROAD's and the Installer's liability, should a future 3rd party or incident affect compliance integrity.

## Health & Safety

**Installation in or on water-borne equipment is not recommended and is not covered by EROAD's warranty.**

**This device is factory-sealed; tampering will void the warranty.**

EROAD expects installers and contractors to understand and follow all relevant health and safety regulatory requirements.

The Installer must wear appropriate Personal Protective Equipment (PPE) for the install risk and customer requirements. PPE may include safety glasses, safety shoes, work gloves, hard hat, high visibility vest, sun cream, sun hat and coveralls. The Installer must understand and comply with the safety requirements of customers or third parties.

Avoid fitting EROAD-supported equipment in locations that could impede or cause injury to people. This includes potential head strike zones on the windshield or dashboard, airbag deployment locations, seatbelts, and other safety-relevant devices.

The vehicle must be parked and level, with the parking brake engaged.

Before installation, check that other safety-relevant equipment is working properly and report any issues to the customer.

Avoid working under suspended loads – held aloft with slings, hoists, or jacks – but if necessary, secondary controls should be in place.

When working at heights, ensure relevant equipment is secured to prevent collapse or falls. A ladder should be used when working at heights up to 2 m (7 ft). For heights above this, such as reaching the top of a freight trailer, the use of a scissor-lift, forklift basket, or similar stable, load-bearing platform is recommended.

Avoid running cables close to heat sources, sharp edges, obstacles or safety-relevant devices.

After installation, check that all other safety-relevant equipment continues to work properly.

While EROAD-supported devices are comprehensively tested against corrosion and ingress, devices are not invulnerable to water, fire or impact damage, and certain devices are not able to be environmentally shielded. Do not subject EROAD-supported devices to extreme heat, high-pressure water force or other intense physical forces. Operating temperatures for the equipment related to this guide are found in the specifications.

The Installer must ensure they fully understand these instructions before installing an EROAD-supported device and immediately seek advice from a Regional Installation Manager on any matter that is not understood.



## Legal disclaimer

The rules and requirements concerning the lawful and compliant installation and operation of electronic driver aids vary, depending on state, country and regulatory authority. You are required to be familiar with the applicable laws of the locations in which the vehicle will be operated. This includes any rules, orders and codes of practice issued by any regulator governing installation of electronic driver aids, or the lawful monitoring, reporting and management of distracted driving and compliance with road rules and requirements for safe driving.

It is your sole responsibility to install and ensure that each vehicle operator uses the devices and accessories that you install in a manner that complies with the law without causing accidents, personal injury or property damage. To the fullest extent permitted by law, EROAD disclaims all liability and excludes all warranties for installation or use of this device and its accessories.

As EROAD is continuously improving its products, EROAD may make changes to this device at any time, which may not be reflected in this document. Please contact your nearest EROAD office if you require any further assistance.

If you think that the installation of this device may have caused your vehicle's performance to be impeded, please contact EROAD Technical Support immediately to resolve the issue. EROAD is not liable for any costs or expenses incurred by engaging a third party to repair the fault without EROAD's prior consent.



## Specifications

<b>Input voltage</b>	12 / 24V
<b>Power consumption</b>	<ul style="list-style-type: none"> <li>Standby: 13.5 V @ 5.67 mA, 27 V @ 3.39 mA</li> <li>Sleep: 13.5 V @ 62~124 mA, 27 V @ 32~61 mA</li> <li>Between 7-12 W, depending on Camera/SD/SIM/sensor load.</li> </ul>
<b>Camera resolution</b>	Front-facing: 1080p@25fps; Driver-facing: 720p@20fps
<b>Field of view</b>	<ul style="list-style-type: none"> <li>Front horizontal: 123°</li> <li>Front vertical: 65°</li> <li>Driver: 140°</li> </ul>
<b>Audio</b>	<ul style="list-style-type: none"> <li>Built-in mic (default OFF)</li> <li>Speaker power: 3W, with adjustable volume</li> </ul>
<b>Status lights</b>	Power: Green On/ Off Alarm: Triple-Flash Red (Alarm)/ Off GPS: Red (Abnormal)/ Red flash (Poor positioning)/Off (normal) Network: Red (Abnormal/ Off (Normal) Wi-Fi: Green (AP mode)/ Red (Abnormal)/ Off (Normal) Camera: Red (Fault, Privacy mode fail)/ Off (Normal)
<b>Storage</b>	MicroSD card×2 (SDXC 256GB), Class 10 or above
<b>Recording time</b>	Dependent on MicroSD card size and additional cameras (eg. Fatigue camera)
<b>Sensors</b>	<ul style="list-style-type: none"> <li>6-axis IMU for acceleration/rotation</li> <li>ambient light for day/night switching</li> </ul>
<b>Ports</b>	USB Mini, MP2 SIM Card x2, RS232, I/O, CAN
<b>GPS</b>	GPS L1, GALILEO, GLONASS, SBAS: WAAS, EGNOS, MSAS, GAGAN
<b>Cellular networks</b>	<ul style="list-style-type: none"> <li>USA: AT&amp;T, T-Mobile, Cincinnati Bell, Immix, CommNet Wireless</li> <li>CAN: Bell Mobility, Telus, Videotron, SaskTel</li> <li>MEX: Telcel, IUSACell</li> <li>AUS: Telstra</li> <li>NZL: Vodafone GDSP</li> </ul>
<b>Dimensions</b>	113.0 × 67.8 × 88.2 mm (4.5 x 2.7 x 3.5 in), excluding bracket
<b>Weight</b>	300 g (10.5 oz)
<b>Ingress Protection</b>	IP30 (Not waterproof)
<b>Operating temp.</b>	-40°C ~ +70°C (-40°F ~ +158°F)



## Powerbox

<b>Power Input</b>	9-36 V
<b>12V Power Out *3</b>	12 V @1 A
<b>12V Power Out *2</b>	12 V @1.5 A
<b>'SEAT' port</b>	12 V @3 A (Only seat vibrator. It can control the switch through the control line)
<b>24 V Power Out*2</b>	24 V @1.25 A
<b>IN</b>	PIN9-M16
<b>OUT</b>	PIN4-M12, PIN6-M12
<b>Dimension</b>	149 x 99 x 43.3 mm
<b>Operating Temperature</b>	-30°C – +70°C

## Datahub

<b>Input voltage</b>	9-36 V
<b>Standby current</b>	2 mA
<b>Power output</b>	5 V @500 mA, 12 V @ 500 mA
<b>RS232</b>	2 channels
<b>RS485</b>	2 channels
<b>Alarm input</b>	8 channels
<b>Alarm output</b>	2 channels
<b>CAN</b>	1 channel
<b>Operating temp.</b>	-20 ~ +70°C

## EROAD Fatigue camera

<b>Input voltage</b>	PON (DC9-16V)
<b>Consumption</b>	~ < 2.4 W
<b>Dimensions</b>	98H x 30W x 43D mm (excluding mounting options)
<b>Weight</b>	230 g
<b>Resolution</b>	800 x 1280 px @20 fps
<b>Network port</b>	10M/100M Adaptive Ethernet Port (Six core aviation head and car connector head optionally)
<b>Infrared lighting</b>	940 nm
<b>Ingress Protection</b>	IP53



---

<b>Operating temp</b>	-40°C – +70°C
-----------------------	---------------

---

## **EROAD Seat shaker**

---

<b>Input voltage</b>	12 V
----------------------	------

---

<b>Dimensions</b>	132 x 60 x 78 mm (inc. molded mounting plate)
-------------------	---

---

<b>Weight</b>	580 g
---------------	-------

---

<b>Ingress Protection</b>	IP54
---------------------------	------

---



## Clarity Edge Cover



This document covers the installation of the Clarity Edge 1.0 system, including the optional Fatigue camera, and optional Seatshaker.

The 1.0 system includes the Power module v1.0, and the Seatshaker's Datahub.

### Technical support

<b>North America</b>	1-855-503-7623	<a href="mailto:support@eroad.com">support@eroad.com</a>
<b>Australia</b>	1800 437 623	<a href="mailto:support@eroad.com.au">support@eroad.com.au</a>
<b>New Zealand</b>	0800 437 623	<a href="mailto:support@eroad.co.nz">support@eroad.co.nz</a>



FCC ID: 2AM6L-ADP2